

Rochester Institute of Technology

RIT Digital Institutional Repository

Theses

1980

Design Considerations for a General Purpose Sensitometer

Robert Goldy

Follow this and additional works at: <https://repository.rit.edu/theses>

Recommended Citation

Goldy, Robert, "Design Considerations for a General Purpose Sensitometer" (1980). Thesis. Rochester Institute of Technology. Accessed from

This Thesis is brought to you for free and open access by the RIT Libraries. For more information, please contact repository@rit.edu.

DESIGN CONSIDERATIONS FOR A
GENERAL PURPOSE SENSITOMETER

by

Robert B. Goldy

A thesis submitted in partial fulfillment
of the requirements for the degree of
Bachelor of Science in the School of
Photographic Arts and Sciences in the
College of Graphic Arts and Photography
of the Rochester Institute of Technology

May, 1980

Signature of the Author.....Robert B. Goldy.
Photographic Science
and Instrumentation

Certified byJ. F. Carson.
Thesis Adviser

Accepted by.....J. F. Carson.
Supervisor, Undergraduate Research

ACKNOWLEDGEMENT

The author wishes to thank Mr. Joe Altman of Eastman Kodak Company, for his advice at the conception of this work, Professor John Carson, who advised the thesis work and to the United States Central Intelligence Agency which supplied financial support.

TABLE OF CONTENTS

	<u>Page</u>
LIST OF FIGURES.....	iv
LIST OF TABLES.....	v
INTRODUCTION.....	1
Footnotes to Introduction.....	3
THEORY.....	4
I. A.N.S.I. STANDARDS.....	4
II. SHUTTER SYSTEM.....	5
A) EXPOSURE CONSIDERATIONS.....	5
B) GEOMETRY OF LAMPHOUSE AND SHUTTER..	6
C) CHARACTERISTICS OF THE UNIBLITZ SHUTTER.....	7
D) SHUTTER ELECTRONICS.....	9
E) CONTROL TIMER.....	9
III. MODIFICATIONS OF THE KODAK I01 SENSITOMETER.....	12
Footnotes for Theory.....	18
EXPERIMENTAL RESULTS.....	20
I. CALIBRATION.....	20
II. REPEATABILITY.....	21
CONCLUSION.....	23
REFERENCES.....	24
APPENDIX.....	25

LIST OF FIGURES

<u>Figure</u>		<u>Page</u>
1	GEOMETRY OF LAMPHOUSE AND FILM PLANE.....	7
2	ILLUMINANCE AS A FUNCTION OF TIME.....	8
3	BASIC TIMER CIRCUIT.....	10
4	CAPACITANCE AS A FUNCTION OF TIME AND RESISTANCE.....	12
5	SCHEMATIC DIAGRAM OF MODIFIED KODAK 101.....	16
6	SCHEMATIC OF SHUTTER SYSTEM.....	17

LIST OF TABLES

<u>Table</u>		<u>Page</u>
1	EXPOSURE TIMES.....	4
2	TIMING CHARACTERISTICS.....	11
3	VALUES OF RESISTORS SELECTED.....	14
4	LUMINOUS OUTPUT FOR EACH SHUTTER DURATION.....	20
5	OUTPUT (LUX-SEC).....	21
6	SYSTEM PERFORMANCE.....	21

ABSTRACT

A Kodak model 101 sensitometer has been improved from the original design and is now able to follow A.N.S.I. standards for exposure of almost all sensitized products. Improvements made on the machine include the addition of an electromagnetic actuated shutter that is timed by an accurate integrated circuit timer that has the capability of six exposure times ranging from 1/100 sec. to 1 sec. This replaces a sector shutter that was motor driven and timed by a mechanical method. Simplicity of use has been maintained since the only new controls are a set of pushbutton switches to select the exposure time. The shutter system was found to perform with a +2% repeatability that is well within A.N.S.I. standards.

INTRODUCTION

Before the conception of this project, the Rochester Institute of Technology did not have a precision sensitometer capable of a range of exposure durations that follow the standards for sensitometry of films and papers as recommended by the American Standards Institute.

In 1978, John J. Lumia modified a Kodak model 101 sensitometer for his undergraduate thesis work. In this work he installed a xenon flash source and replaced the tungsten source with a tungsten-halogen source. The addition of the xenon source served two basic needs in sensitometry. First, photography often utilizes xenon sources and it is advantageous to sensitometrically test film under conditions similar to that of actual use. Secondly, a xenon source has a spectral output that is similar to that of daylight, which makes it ideal for the testing of daylight films. The addition of a tungsten-halogen source allows for a much longer lamp life.

In addition to this he modified the existing sector shutter so that an exposure duration of $1/20$ second would be obtained instead of the standard $1/5$ second for the 101 sensitometer.

Recent developments in electronics make the rotating

sector shutter with electro-mechanical timing obsolete. This system is limited to one exposure duration and does not follow the A.N.S.I. standards for a wide range of sensitized materials. It is now possible to use an electro-mechanical leaf shutter with an integrated circuit timer that has close tolerances on exposure repeatability.

The purpose of this work is to extend the work of Lumia and to produce a sensitometer that has greater versatility through the use of an electro-actuated shutter that is electronically timed and controlled.

The work set forth herein investigates exposure consideration and the standards on which they are based. The shutter system has been detailed, and a section describing the modifications made to the sensitometer is included. Methods used and the results of testing of the system are included in the section on experimental results.

FOOTNOTES FOR INTRODUCTION

1. Lumia, J. J. A General Purpose Sensitometer for Routine Sensitometric Testing, Undergraduate thesis work performed at the Rochester Institute of Technology, 1978

THEORY

I. A.N.S.I. Standards

In the design of a sensitometer for general use it is important to consider A.N.S.I. standards which provide universal standards for sensitometry of films and papers. A.N.S.I. standards cover the subject of sensitometry thoroughly with specific standards on exposure, method of attenuation and the spectral power distribution of the source. Table 1 provides a summary of the A.N.S.I. standards which deal with exposure duration.^{2,3,4,5,6}

<u>Material Type</u>	<u>EXPOSURE TIMES</u> <u>Exposure Time (seconds)</u>
Photographic Paper	0.1 to 10
Negative Material	1/80 to 1/20
Color Reversal	
Daylight	1/1000 to 1/25
Tungsten	1/100 to 5.0
Color Negative	
Daylight	1/1000 to 1/25
Tungsten	1/100 to 5.0

A.N.S.I. Standards also cover the quality of the exposure. It is stated that the exposure must be determined in absolute photometric units and be maintained within +5%

or $\pm 0.02 \log E$ units. ^{7,8,9,10,11} This standard is of considerable importance and will be thoroughly investigated in the study of the completed sensitometer. The sensitometer shutter must provide a single exposure that is modulated with spectrally flat neutral density filters and step tablet. ¹²⁻¹⁶ The quality of radiant energy incident on the sample must be that of a blackbody radiator at a temperature of 3000 ^{o 17,18,19,20,21} ± 25 K. Keeping these basic criterion in mind, the basic ideas for the design of a sensitometer have been stated.

II. Shutter System

A) Exposure Considerations

Following the A.N.S.I. standards for exposure times it was determined that a range of 1/100 second to 1.0 second would be useful and provide the user a selection for his work. First, it is important to consider the exposure of 1/100 second. It was determined that an exposure duration shorter than this would lead to exposure instability because the tungsten-halogen source operates on alternating current at 60 cycles/second. An exposure shorter than 1/120 second would exhibit irregularity in exposure control due to the ripple in the lamp's output.

Also of consideration is the amount of exposure possible at 1/100 second. The design of Lumia led to a lamp output of 1500lux at the film plane, yielding 15 lux-seconds, which

is within a useful range for higher speed films, but would not be of use for slower films and papers.

B. Geometry of Lamphouse and Shutter

The geometry of the system plays a large role in the selection of a shutter. The shutter must be of a size and configuration to allow for the even distribution of illumination across the film plane. This is achieved by maintaining that the entire lamp filament must be in a geometric direct path at each point on the film platen.

The model 101 sensitometer has an enclosed lamphouse that is located on a sliding track for the adjustment of illuminance on the film. The shutter must be large enough and at such a distance from the lamp that the filament can be observed at all points while the lamphouse is at the closest position to the film platen.

The following scheme was developed to compute the geometry needed. It was felt that a one-inch aperture shutter would be used (see section II.-C). From this a determination of the distance at which the shutter must be from the lamp was determined.

A baffle is in the sensitometer at a point in front of the film platen. It was determined that if this aperture was filled the geometry would be as desired. Figure 1 shows the geometry of the system. Using a simple proportion the value of Q can be determined.

GEOMETRY OF LAMPHOUSE AND FILM PLANE

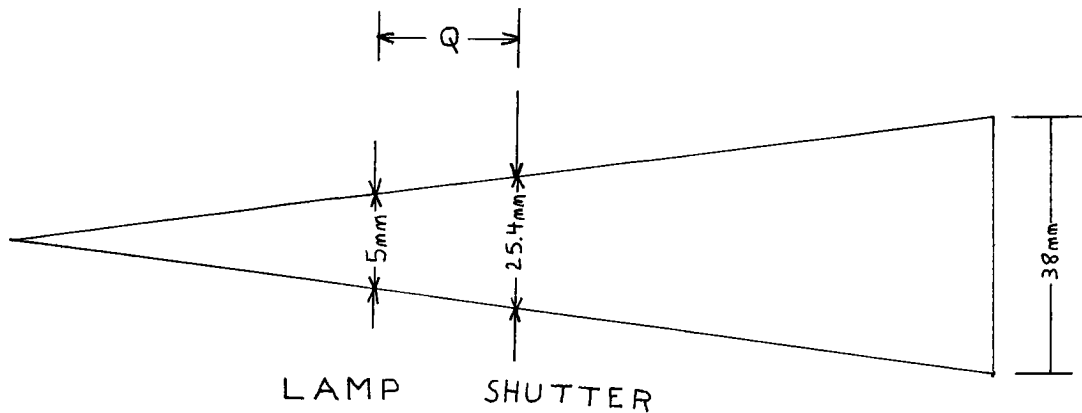

FIG. 1

C. Characteristics of the Uniblitz Shutter

It was determined that the Uniblitz shutter manufactured by A.W. Vincent Associates, Inc. follows the considerations needed for the sensitometer. ²² The shutter is composed of two blades that are actuated by an electromagnetic coil. The blades are coated with a highly buffed stainless steel coating that is able to reflect over 80% of the light incident on it, thus eliminating the danger of the blades warping from the heat.

When studying a particular shutter there are some general assignments that can be made as to its performance. ²³

Exposure is defined as:

$$H = E \times t$$

where H = Exposure

E = Illuminance

t = Time

For an actual shutter, such as the Uniblitz, there is an opening and closing time in which the illuminance becomes a function of time. This is shown by the equation:

$$H = \int_{t_0}^{t_0 + T} E dt$$

where T = Total Open Time

This can be shown graphically as illuminance as a function of time. See Fig. 2

ILLUMINANCE AS A FUNCTION OF TIME

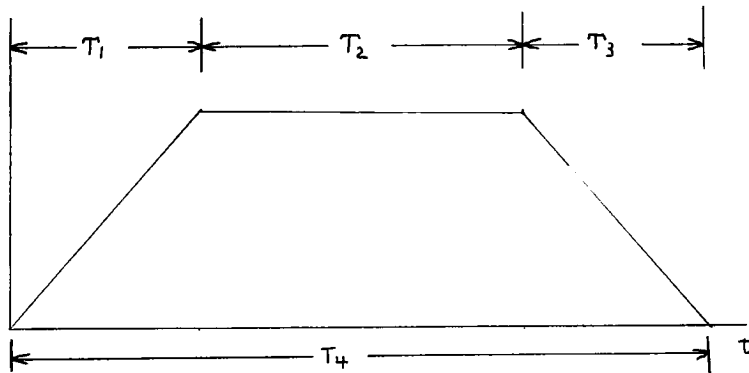

- T₁ is the Opening Time
- T₂ is the Fully Open Time
- T₃ is the Closing Time
- T₄ is the Total Operative Time

FIG. 2

In choosing shutter times it is necessary to consider the discrepancy between the effective shutter time and that of the actual shutter time in order to determine the value of resistance in the timers. Assuming that $E(t)$ as a function of time is linear, then the effective shutter time (T_e) is:

$$T_e = T_t - \frac{T_1 + T_3}{2}$$

The ratio between the effective shutter time and the total shutter time can be used as a measure of the efficiency (Z) of the shutter such that:

$$Z = \frac{T_e}{T_t}$$

Listed in Table 2 are the values of T_e desired, their corresponding total times necessary to produce the desired shutter duration, and the efficiency of the shutter at each value.

<u>T_e (m.sec.)</u>	<u>T_t (m.sec.)</u>	<u>% Efficiency</u>
1000	1001.78	99.8
500	501.78	99.6
200	201.78	99.1
100	101.78	98.3
20	21.78	91.8
10	11.78	84.9

As can be seen by the discrepancy between the effective and total time, particularly at short exposure times, there will be a necessity to design the timing circuit so that the total time will be produced by the timer. In doing so, the effective value that is desired will be obtained.

D. Shutter Electronics

The shutter is operated by a drive unit also manufactured by A.W. Vincent Associates, Inc.²⁴ The model chosen was the 100-B which operates on 117 Volts. This unit is essentially a power supply that provided an initial 60 Volts D.C. pulse to the open shutter. 10 Volts D.C. is maintained for its open duration.

The drive unit is triggered by a positive logic signal from a timer at a current of 1 m.A. The drive unit also puts out a constant 10 Volts D.C. that can be used to operate an I.C. timer circuit. For a schematic of the shutter electronics, see Fig. 6.

E. Control Timer

As previously stated the drive unit needs a logic signal with a voltage above 5 volts at a current of 1 m.A. It was determined that an integrated circuit timer such as the 555 timer would meet the necessary requirements of voltage and current. This timer is contained in an 8 pin package and requires a minimum of additional components for its use.

The timer is stated to have a stability that is better

than 0.005%/°C. The accuracy of the device is so great that it will cause no apparent deviation of the exposure duration.

The 555 timing is determined by a resistance-capacitance circuit in which the charge rate of the capacitor determines its output duration. The output is 0 Volts D.C. until it has been triggered. Then a voltage is produced that is the same as the input. Fig. 3 shows a basic timer circuit that can be used for a variety of timing applications. The timing is controlled by the values of R_a and C_1 .

BASIC TIMER CIRCUIT

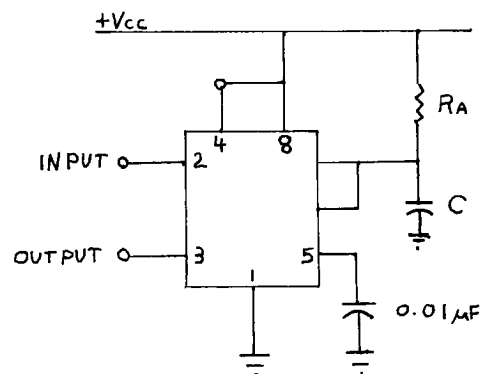

FIG. 3

To determine the output duration of the 555 timer, the following equation is used:

$$t_w = 1.1 R_a C$$

This can be shown graphically as capacitance as a function of time and resistance. See Fig. 4.

CAPACITANCE AS A FUNCTION OF TIME AND RESISTANCE

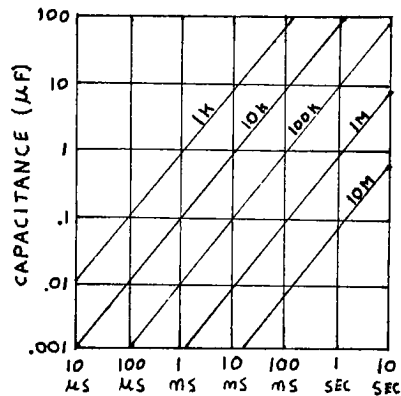

FIG. 4

To incorporate six exposure durations it is necessary to use either six capacitors or six resistors. It was determined to be much simpler to use a single capacitor and six resistors since the number of resistor sizes available is greater. Also, a potentiometer can be used which will allow for calibration of the exposure duration.

III. Modifications of the Kodak 101 Sensitometer

In order to modify the sensitometer (R.I.T. #62742), all of the original shutter components and wirings were removed. This necessitated the covering of holes left in the

lamphouse. This was accomplished by bolting sheet metal over the hole.

The shutter was mounted at a distance of 16 mm. from the lamp. A mount was made that had a thickness of 11 mm. The shutter and shutter mount were located on the inside front of the lamphouse with #3-56 machine screws that were tapped into the lamphouse.

The considerations developed in the previous section have been followed in the construction of the timing circuits. For the actual use of the 555 timer it is necessary to properly trigger the device. Triggering is accomplished by connecting pin #2 to ground through a capacitor. Before triggering can occur, pin #2 must be at a positive state. To produce this state, it was determined that a push-button switch that has two open states would work. When the sensitometer is in a standby state, the switch puts +10 V. onto pin #2. When the actuation button is pushed, this positive voltage is removed and pin #2 is grounded, starting the exposure cycle. This switch is located on the right side of the sensitometer in the same location that the switch for the sector shutter was located.

The timing circuits were constructed on pre-drilled circuit board that is designed to be used for integrated circuits. This board has square copper solder points on the underside that allow for ease of construction of the circuits. The circuit board was mounted on the inside wall of the

sensitometer directly above the powerstat. It is positioned so that the potentiometers that are used to control the timing are located at the top of the sensitometer to enable convenient calibration. The drive unit is located on the cover to the internal electronics in a position once occupied by the motor of the sector shutter.

Using the method of selecting values for R_a and C as stated in a previous section, it was determined that a 1.0 uF capacitor would allow for a convenient range of resistor values. The selections are listed in Table 3 below.

TABLE 3 VALUES OF RESISTORS SELECTED

<u>Exposure Duration(sec)</u>	<u>R_a Needed</u>	<u>Potentiometer Used</u>
1	193 K	200 K
1/2	97 K	100 K
1/5	39 K	50 K
1/10	19.3 K	20 K
1/50	3.9 K	5 K
1/100	1.9 K	5 K

Selection of shutter time is made by the user through a set of connected push-button switches that allow only one resistor to be used at a time. It was determined that if a switch was partially depressed and then released, the resistor would be completely disconnected. In this state the capacitor in the timer circuit does not discharge and causes the shutter to remain open indefinitely. This could be used to produce

exposure durations greater than one second if desired. For a complete schematic of the sensitometer see figures 5 and 6.

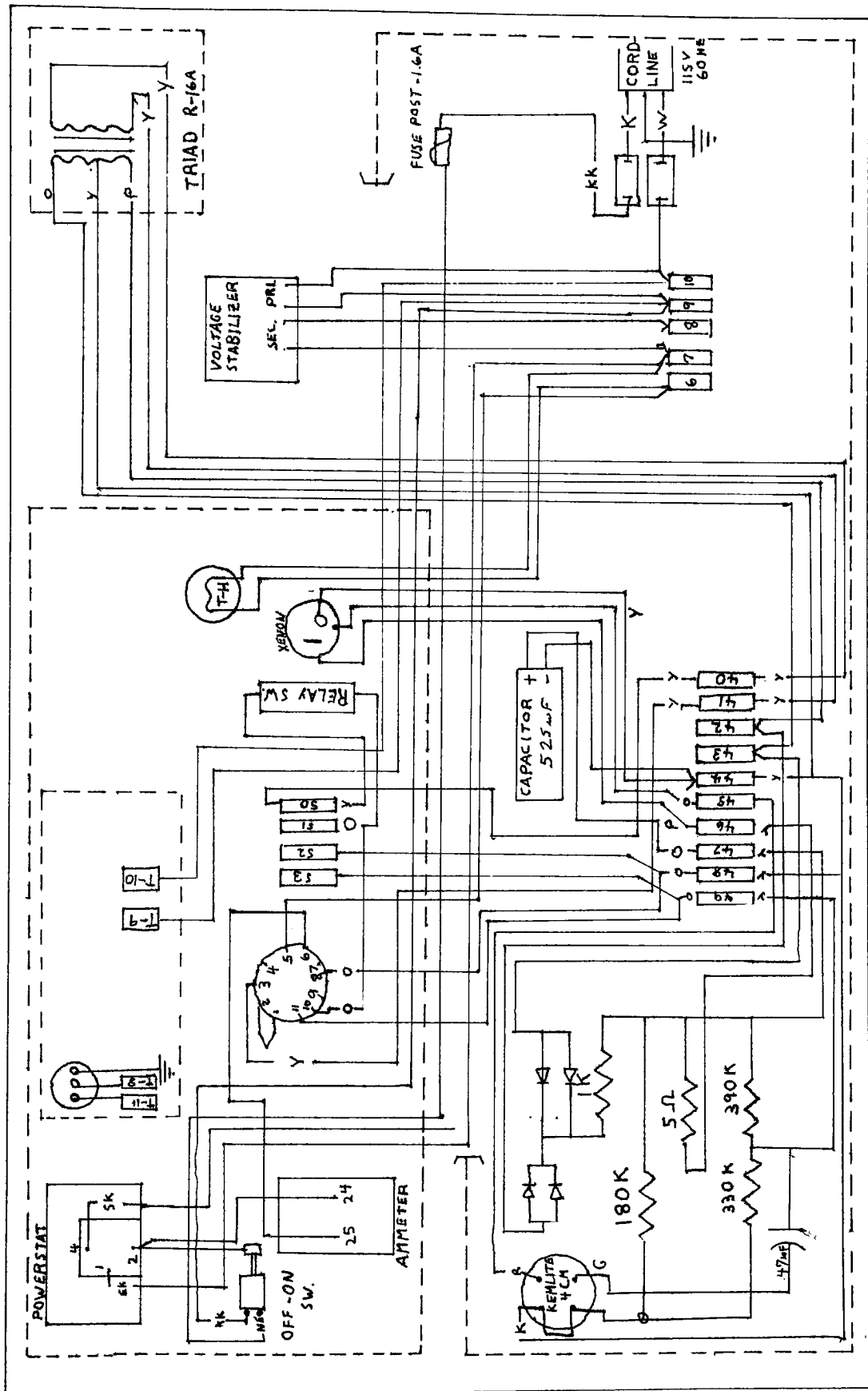

FIG. 5

SCHEMATIC OF SHUTTER SYSTEM

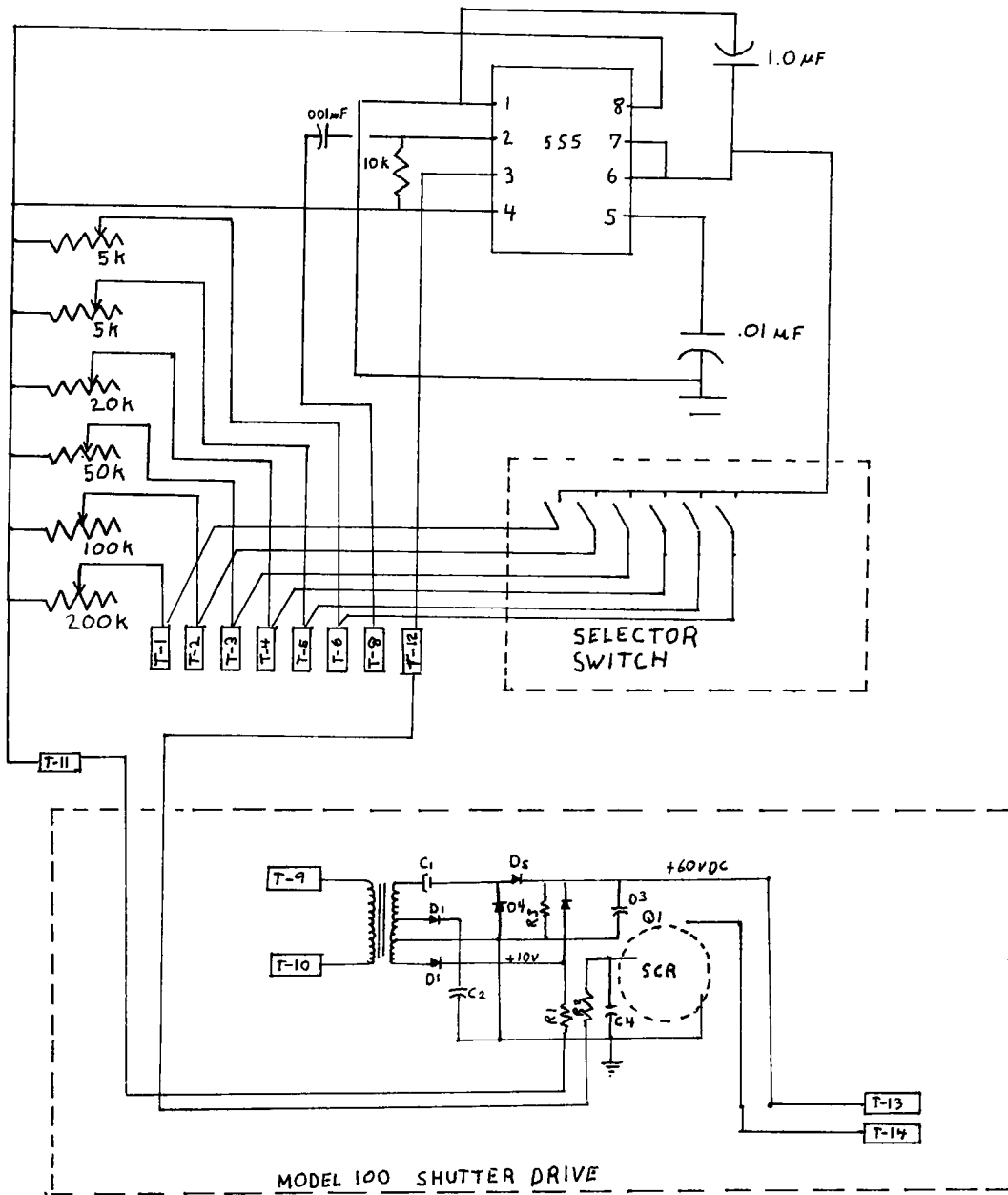

FIG. 6

FOOTNOTES FOR THEORY

2. American National Standards Institute (A.N.S.I.), standard PH2.2-1966, Sensitometry of Photographic Paper

3. A.N.S.I., standard PH2.21-1979, Method for Determining the Speed of Color Reversal Films for Still Photography

4. A.N.S.I., standard PH2.27-1979, Method for Determining the Speed of Color Negative Films for Still Photography

5. A.N.S.I., standard PH2.5-1972, Method for Determining the Speed of Photographic Negative Material

6. A.N.S.I., standard PH2.21-1979

7. A.N.S.I., standard PH2.27-1979

8. A.N.S.I., standard PH2.5-1972

9. A.N.S.I., standard PH2.2-1966

10. A.N.S.I., standard PH2.21-1979

11. A.N.S.I., standard PH2.27-1979

12. A.N.S.I., standard PH2.5-1972

13. A.N.S.I., standard PH2.2-1966

14. A.N.S.I., standard PH2.21-1979

15. A.N.S.I., standard PH2.27-1979

16. A.N.S.I., standard PH2.5-1972

17. A.N.S.I., standard PH2.2-1966

18. A.N.S.I., standard PH2.21-1979

19. A.N.S.I., standard PH2.27-1979

FOOTNOTES FOR THEORY
(Continued)

20. A.N.S.I., standard PH2.5-1972
21. A.N.S.I., standard Ph2.2-1966
22. A.W. Vincent Associates, inc. catalog UNIBLITZ
revised 4/79
23. Carson, J. Introduction to Photographic Optics,
RIT 1979
24. A.W. Vincent Associates, inc.
25. Seidman, A. and Waintraub, J. Electronics.
Charles E. Merrill Publishing Company, 1977, p. 481

EXPERIMENTAL RESULTS

I. Calibration

Calibration of the sensitometer was performed by using the E.G.&G., Inc. model 550-1 Radiometer/Photometer. Lumia calibrated the sensitometer to produce a color temperature of 2856 K at a current of 0.86 amps. Using this setting, the lamphouse was positioned at +.5 to produce an illuminance of 1500 lux. Using this as the constant output for the various shutter times were determined. Table 4 shows the aim values desired.

TABLE 4 LUMINOUS OUTPUT FOR EACH SHUTTER DURATION

Time (sec.)	Output (Lux-sec.)
1	1500
1/2	750
1/5	300
1/10	150
1/50	30
1/100	15

These aim values were then tested by using the Radiometer in an integrating mode. The potentiometers were adjusted to attain the desired outputs.

II. Repeatability

In order to determine the repeatability of the shutter for the various exposure durations, 30 samples were taken for each. The mean, standard deviation, and variance were determined. Data appears in appendix A.

<u>Time (sec.)</u>	<u>Mean</u>	<u>Standard Deviation</u>	<u>Variance</u>
1	1507	9.4	.086
1/2	740.6	6.4	.040
1/5	309.2	2.97	.0851
1/10	149.1	3.18	0.98
1/50	30.6	0.32	.0101
1/100	15.1	0.32	.01

To assign a percent repeatability to the system, 3 sigma limits were used and are shown in table 6.

<u>Time (sec.)</u>	<u>3σ</u>	<u>±% Accuracy</u>	<u>Lux-sec Range</u>
1	28.2	1	1507+ <u>28.2</u>
1/2	19.2	2	740.6+ <u>19.2</u>
1/5	8.91	2	309.2+ <u>8.91</u>
1/10	9.54	6	149.1+ <u>9.54</u>
1/50	.96	3	30.6+ <u>.96</u>
1/100	.96	2	15.1+ <u>.96</u>

The shutter duration of 1/10 sec. was found to have a greater deviation than the other exposure times. This can be easily explained by the timer circuit that was used. For the resistance needed, potentiometers were employed. These potentiometers were of a type that needed 15 turns to cover the range of the potentiometer. Due to a lesser availability of these potentiometers, a less reliable single turn potentiometer that appeared to be much less stable was used.

CONCLUSION

Based on the results, the Kodak 101 sensitometer has been successfully modified to include six exposure durations and the ability to perform time exposures. The system was determined to have an assignable repeatability that falls within within the $\pm 5\%$ dictated by the A.N.S.I. standards. All of the repeatability is within $\pm 3\%$ except for the 1/10 sec. exposure. It was noted that the cause of this was the type of resistor used in the timing circuit and by replacing this, 1/10 sec. would also have accepted repeatability. It was determined that the Uniblitz shutter provided accurate exposure and appears to have the qualities necessary for general purpose sensitometry.

REFERENCES

- Lumia, J.J. A General Purpose Sensitometer for Routine Sensitometric Testing, Undergraduate thesis work performed at the Rochester Institute of Technology, 1978
- American National Standards Institute, standards PH2.2-1966, PH2.21-1979, PH2.27-1979, PH2.5-1972.
- A.W. Vincent Associates, inc. catalog UNIBLITZ revised 4/79
- Carson, J.F. Introduction to Photographic Optics, RIT 1979
- Seidman, A. and Waintraub, J. Electronics
Charles E. Merrill Publishing Company, 1977, p. 481

APPENDI X

Appendix A-1 Exposure Repeatability Data at 1 Sec.

<u>Sample Number</u>	<u>Lux-Sec.</u>	<u>Sample Number</u>	<u>Lux-Sec.</u>
1	1520	16	1500
2	1500	17	1500
3	1490	18	1510
4	1510	19	1490
5	1500	20	1510
6	1500	21	1510
7	1500	22	1500
8	1500	23	1510
9	1520	24	1520
10	1500	25	1500
11	1520	26	1520
12	1500	27	1500
13	1520	28	1520
14	1510	29	1510
15	1500	30	1510

Mean = 1507 lux-sec.

Standard Deviation = 9.4

Variance = .09

Appendix A-2 Exposure Repeatability Data at 1/2 Sec.

<u>Sample Number</u>	<u>Lux-Sec.</u>	<u>Sample Number</u>	<u>Lux-Sec.</u>
1	760	16	740
2	750	17	730
3	750	18	740
4	740	19	730
5	740	20	730
6	740	21	750
7	740	22	740
8	740	23	740
9	740	24	740
10	740	25	740
11	740	26	740
12	750	27	740
13	730	28	740
14	740	29	740
15	740	30	740

Mean = 740.6

Standard Deviation = 6,4

Variance = 0.0395

Appendix A-3 Exposure Repeatability Data at 1/5 Sec.

<u>Sample Number</u>	<u>Lux-Sec.</u>	<u>Sample Number</u>	<u>Lux-Sec.</u>
1	310	16	307
2	311	17	317
3	309	18	315
4	309	19	312
5	308	20	307
6	309	21	311
7	311	22	314
8	306	23	306
9	304	24	305
10	308	25	306
11	308	26	311
12	308	27	310
13	307	28	306
14	310	29	312
15	310	30	310

Mean = 309.2

Standard Deviation = 2.97

Variance = .0851

Appendix A-4 Exposure Repeatability Data at 1/10 Sec.

<u>Sample Number</u>	<u>Lux-Sec.</u>	<u>Sample Number</u>	<u>Lux-Sec.</u>
1	147	16	147
2	146	17	152
3	153	18	146
4	145	19	148
5	151	20	146
6	147	21	152
7	153	22	151
8	152	23	148
9	149	24	146
10	151	25	145
11	144	26	148
12	146	27	152
13	152	28	156
14	154	29	150
15	153	30	146

Mean = 149.1

Standard Deviation = 3.18

Variance = 0.98

Appendix A-5 Exposure Repeatability Data at 1/50 Sec.

<u>Sample Number</u>	<u>Lux-Sec.</u>	<u>Sample Number</u>	<u>Lux-Sec.</u>
1	30.5	16	30.3
2	30.4	17	30.3
3	30.4	18	31.2
4	30.5	19	31.2
5	30.7	20	31.2
6	30.6	21	30.4
7	30.9	22	30.5
8	31.1	23	30.9
9	30.6	24	30.2
10	30.1	25	30.1
11	30.7	26	30.5
12	30.6	27	30.5
13	30.4	28	30.5
14	31.0	29	30.2
15	30.8	30	30.3

Mean = 30.59

Standard Deviation = 0.32

Variance = 0.01

Appendix A-6 Exposure Repeatability Data at 1/100 Sec.

<u>Sample Number</u>	<u>Lux-Sec.</u>	<u>Sample Number</u>	<u>Lux-Sec.</u>
1	15.0	16	14.6
2	14.8	17	15.5
3	14.8	18	15.4
4	15.0	19	15.5
5	14.8	20	15.2
6	15.3	21	15.6
7	14.8	22	15.7
8	14.8	23	15.2
9	15.1	24	15.8
10	14.8	25	15.2
11	14.9	26	15.2
12	14.8	27	15.2
13	14.9	28	15.2
14	15.0	29	15.5
15	15.9	30	15.6

Mean = 15.14

Standard Deviation = 0.32

Variance = 0.01