

Analog vs Digital shutter control on 35mm Reflex Film camera PART 1

It was the early 1970s, and 35mm camera manufacturers were introducing electronic focal-plane shutter control, particularly to enable automatic aperture priority, simplify the speed control mechanism and simplify adjustment.

(Example: Minolta XM, XE-1, Leica R3, Cannon F1, Minolta XD, XG, XM, ...).

Then, in the late 1970s and early 1980s, they switched from analog shutter control to digital shutter control (and more) Example: Canon AE-1, Nikon F3, X500, X700.

The heart of the shutter control stage is therefore to manage the exposure time, time between the start of the 1st curtain and the 2nd curtain, nothing more.

The way the exposure duration is managed is very similar in analog or digital.

The way it is implemented is very different.

- Analog design: we use a Ramp signal to create a delayed signal
- Digital: we use a Counter to count the time unit and create delayed signal

Shutter control - Analog vs Digital

1/60 exposure time - 15,625mS curtain speed 8ms for 35mm travel

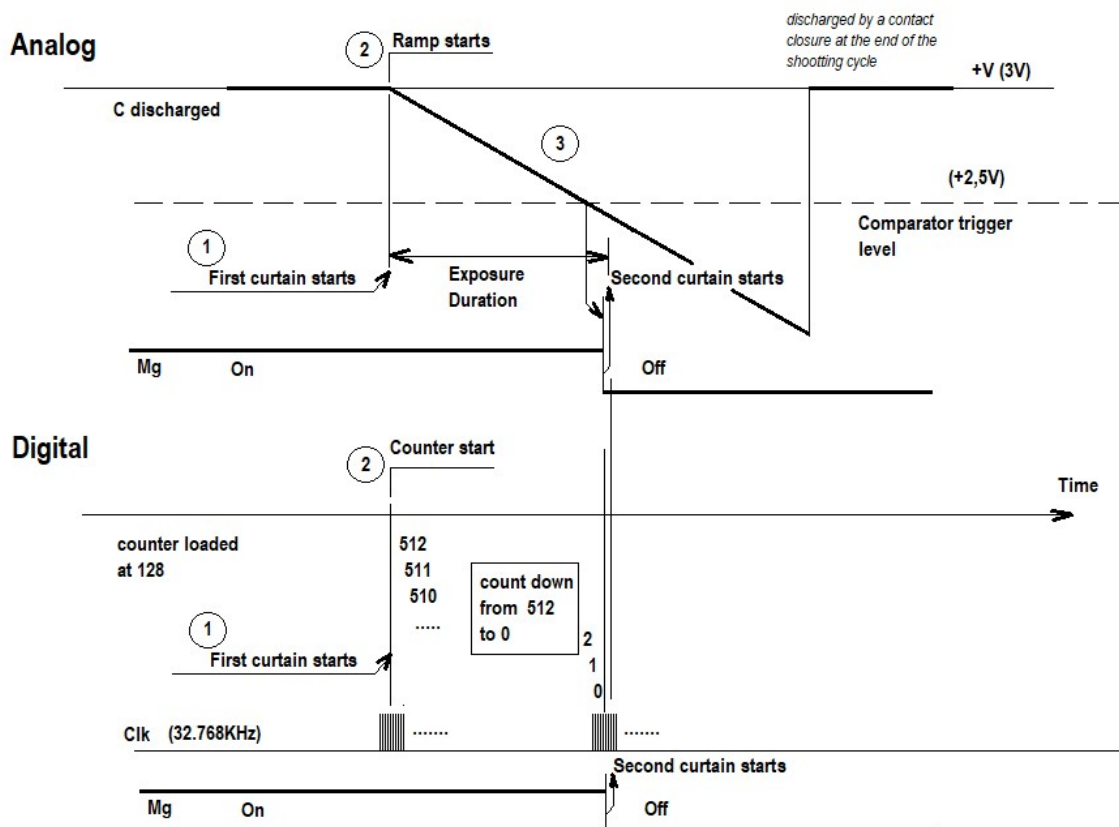

Analog vs Digital shutter control on 35mm Reflex Film camera PART 2

Analog shutter control: How it works.

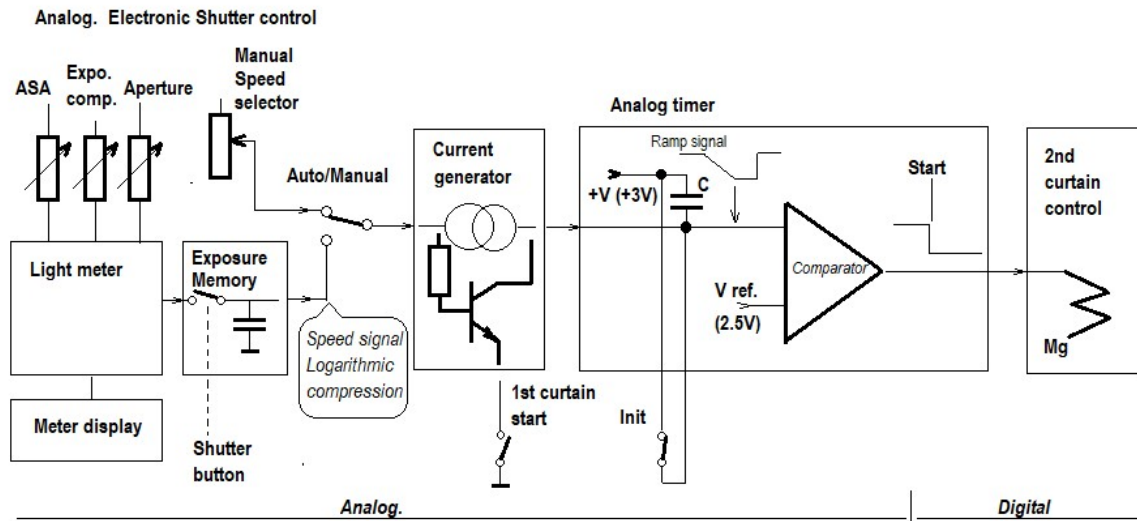

The analog timer stage input and output:

input parameter:

- speed signal ex from 1/2000 to 8s...

control input:

- init (to initialize the circuit)
- start (synchronous to first curtain start, start the timer, in fact start the ramp)

output: start signal of the second curtain

The timer stage is able to create delay corresponding to speed parameter (ex from 0.4 ms to 8s).

At the input, the speed signal can take different voltage value and the voltage value is a direct representation of the speed.

It is easy to create such signal with speed selector (potentiometer) or with the metering system of the camera (Voltage f(Light)).

A ramp signal is created using this input voltage. For that purpose we charge a capacitor C using a constant current generator (transistor). It gives a linear variation of the voltage during a time period. To create the delay we define a certain voltage level at which the Ramp signal will activate the second curtain. For that purpose we use a comparator to compare Ramp signal with a voltage reference. When ramp reach the reference voltage, the comparator output activate the magnet Mg that will permit to start second curtain. In fact, on mechanical side the Mg magnet retain the second curtain during the delay.

As it is analog signal, it is stepless. All voltage value are converted in a delay value or speed value.

To initialize the timer before each shutter cycle: We discharge capacitor C by a switch (activated after 2nd curtain start and until mirror goes up).

To start the timer: we activate the current generator putting Transistor emitter at ground ($V_{\text{speed}} / R = I_b$ flows and create $B \times I_b = I_c$ at the output)

The value of the current controls the exposure duration: high current will quickly charge the capacitor (dv/dt high - short time); low current (dv/dt low) produce long time exposure.

In this example it is for 1/60, and a body with curtain speed of 8ms for 35mm frame window. The comparator stage integrates a delay stage to control the slot width between curtains at high speeds. This is the reason why there is a delay between crossing the trigger threshold and the command of the Mg output.

Speed scale, signal range

The way the speed is "coded" using voltage is simple. It is a logarithmic compression. For each speed increment (we double the time each step) the voltage increase of a constant value. The step is very small to be able to code all the available speed in 0.3V or 0.5 dynamic. It is needed to be able to use 2.5V to 3V power supply for the camera.

Example of progression of the speed signal for a Minolta XM (step is 17.9mV) - Values depend of the manufacturers/body type and sometime adjustment/setup

8s	469,3 mV
4s	487,2 mV
2s	505,1 mV
1s	523,0 mV
1/2	540,9 mV
1/4	558,8 mV
1/8	576,7 mV
1/15	594,6 mV
1/30	612,5 mV
1/60	630,4 mV
1/125	648,3 mV
1/250	666,2 mV
1/500	684,1 mV
1/1000	702,0 mV
1/2000	719,9 mV
1/4000	737,8 mV

Speed signal is stepless all value in mV produce a speed value.

the way it is coded have another advantage. Each step is an EV step. Then, to adjust speed level you have only to add/substrate an offset (gain will stay the same).

It is the way ASA, Exposure compensation and Aperture simulation are working.

Analog vs Digital shutter control on 35mm Reflex Film camera PART 3

Digital implementation

WARNING: This is an example of implementation and not a copy of a precise camera.

In the digital shutter control, the timer stage is digital with a Counter and a Clock.

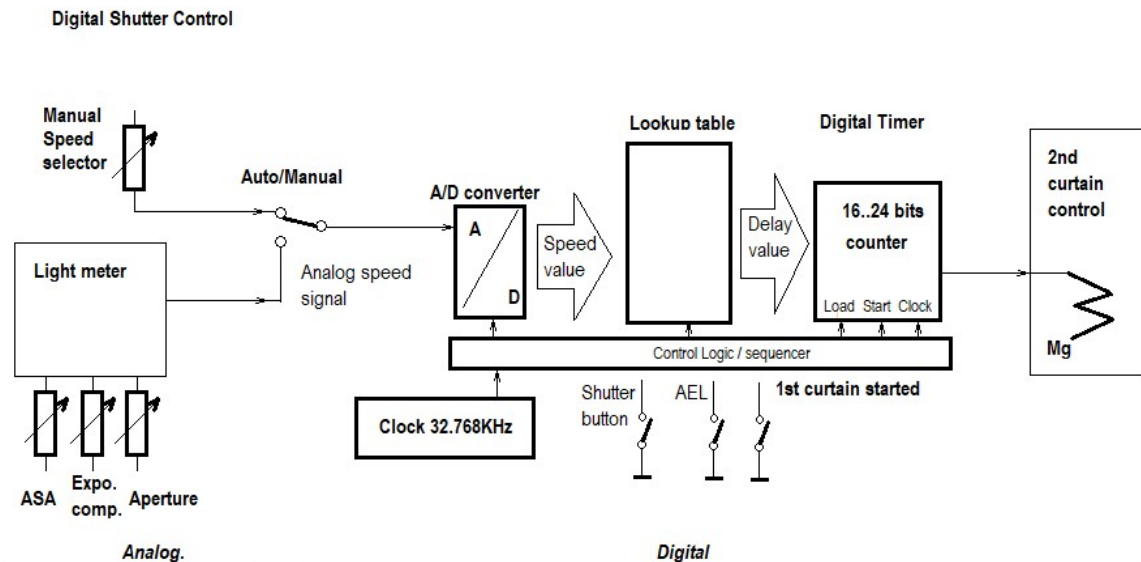

At the Init, we load a delay value in a digital counter. At start we decrement the counter at each period of a Clock signal. When counter reaches 0, the output signal is activated and start 2nd curtain. Counter is stopped.

At the beginning, manufacturer used a 16 bits timer (or more) clocked at 32.768 KHz to deliver the delay and control precisely the 2nd curtain start signal. It permits to have a $30\mu\text{s}$ step and very stable delay from 1/2000 to several seconds with small timer size (16 bits timer). Manufacturer consider the $30\mu\text{s}$ step as "stepless compared" to the impact in EV on the film. At 1/2000 it is 6% of the duration, less than 1/10 IL. In fact the steps depend also how many bits are used to quantify speed. If we consider speed range from 1/2000 to 4s, 14 value, using 1/3 EV resolution it gives 40 speed value, easy to code with 6 bits A/D converter.

The clock is also used by Sequencer Stage to control A/D converter and counter (load delay value in the counter, start count). In several cameras, the clock is divided to generate other delay like: self-timer; Blinking self timer LED display; Meter-On timer; display timer activation.

At the input, the speed parameter stays an Analog signal. This signal can take different voltage value and the voltage value is a direct representation of the speed (scale depend from the manufacturer). This signal is converted to Digital (using Analog/Digital converter) and result converted to delay value using lookup table. The lookup table converts digital speed value to digital duration value. All values are predefined in a integrated memory circuit.

List of shutter speed and time duration ms and digital value (for 32.768 KHz clock

Shutter Speed	Standard value	duration ms	count
4s	4,00s	4000	131072
2s	2,00s	2000	65536
1s	1,00s	1000	32768
1/2	500ms	500	16384
1/4	250ms	250	8192
1/8	125ms	125	4096
1/15	62,5ms	62,5	2048
1/30	31,3ms	31,25	1024
1/60	15,6ms	15,625	512
1/125	7,81ms	7,8125	256
1/250	3,91ms	3,90625	128
1/500	1,95ms	1,953125	64
1/1000	0,977ms	0,9765625	32
1/2000	0,488ms	0,48828125	16

In both implementation analog and digital we have "Exposure memory" feature to memorize the light:

- Before mirror up cycle (even if there is no AEL explicit command)
- On demand by user (AE lock button)

The implementation of memory change and in this case will be at the digital level. Example: We stop A/D conversion to memorize the last value.

The advantage of the digital implementation is : (not exhaustive list)

- Accuracy of the Exposure time. You have only to adjust curtain speed and all is working by design
- simplify the design of the mechanic part, removing many contacts used to synchronize the electronic with mechanic.
- simplify of the display interface (LCD) using the digital speed value (without any adjustment)

With Digital, the sequencer will not be any more a mechanic one. It will be completely electronic and will permit new camera design with and electric control of the shooting cycle: mirror up, aperture closure, shutter start, film advance (winder).

The digital evolution of Film camera was made possible by the increase in density of integrated circuits, the use of flexible printed circuits and subsequently the integration of programmable microcontrollers.

Evolution of Analog input ASA/DIN, Speed, and Aperture

In the end of 1970s, beginning of 1980, manufacturer replace potentiometer by "resistance network" (exact name depend of the manufacturer).

Potentiometers are very interesting because they deliver "stepless" analog values. All level are possible but they are very sensitive to dust and wear.

Some manufacturers have circumvented the problem by coating resistive traces on ceramic, but this resulted in significant costs and contact issue.

Furthermore, in many applications (sensitivity acquisition, exposure correction), it is not necessary to encode all the values (1/3 EV is sufficient).

To simplify, they have all developed variable potentiometers/resistors by combining a resistance network with gold-plated connections, providing high-quality and precise steps.