

# AGFA PCR II PLUS USER MANUAL



## Quick Links

[Camera Modules](#)

# Table of Contents

Audience

Preface • xiii

Purpose

Overview

Introduction

Equipment and Supplies

PCR II Plus Accessory Kit

Professional Films

Color Densitometers

Camera Modules

Controls and Connectors

Front Panel

Rear Panel

Filter Correction and DAC Values

Introduction

Power Connection

Communication with Other Devices

Definitions of Communications Terms

Connecting to a GPIB Interface

Connecting to a SCSI Interface

Guidelines for SCSI Connection

SCSI Interface Single Device Configuration

SCSI Interface Multiple Device Configuration

Internal Termination

Changing Between GPIB and SCSI

Setting Device Addresses

Guidelines

Set Device Address Procedure

Selecting the Display Language

Film Backs and Film

Introduction

Powering On the PCR II Plus

Warm-Up Period

Using the Front Panel Controls

Front Panel

The Ready Message

Function Selections

Resetting the PCR II Plus

When Reset Occurs

Effects of Reset

Reset Defaults

The PCR II Plus Beeper

Introduction

Loading Film

Unloading Film

Advancing Film

Frame Count

Set Film Type

Specifying User Film Type

Currently Supported Film Types

Save LUT

Introduction

Calibration Features

Calibration Functions

Pacing Control

Pacing Values and Imaging Speeds

Setting the Pacing Value

Guidelines for Selecting Pacing Values

Resolution Control

Introduction

Overview of the Process

Response Curves

Channels

Exposing Test Images

Brightness Control

Brightness Units

Setting Brightness

Contrast Control

Contrast Units

Setting Contrast Values

Repeats

When to Use Repeats

Increased Exposure

Repeats and Brightness

Setting the Repeat Value

Tips and Tricks

Film Guidelines

Changes and Default Settings

Dmax and Dmin

Increments and Channels

Trial and Error

Gauging the Effects of Changes

Off-Color Slides

Guidelines for Print Film

Goal Density Tables

Slide Films

Print Films

Introduction

Status and Error Messages

Possible Problems and Solutions

Power Indicator Does Not Illuminate

PCRIIPlus Resets Suddenly

Computer Locks Up on Large Image Files

35mm Film Will Not Load

System Locks Up When You Touch Film Module

Calibration Errors

Calibration Out of Range

Reset Film Type

Reset Defaults

Battery Problems

Reloading Look Up Table Values

Resetting Filter Correction Values

Recurring Battery! Error Messages

Hardware Problems

Macintosh SCSI Interface Troubleshooting

General Image and Rasterization Problems

Technical Specifications

Input

Data Interface

File Formats

Film Formats

Supported Films

Addressability

Power Requirements

Physical

Environmental

EMI/RFI

Safety Standards

Theory of Operation

User Log Tables

Glossary

Primary and Secondary Error Codes

Code 83: Illegal Command Byte

Code 84: Illegal Data Byte

Code 91: Memory Error

Code 92 (PC): GPIB Interface Error

Code 92 (Macintosh): SCSI Interface Error

Code 93: CRT Brightness or Contrast Calibration Error

Code A1: Module Error

Introduction

Attaching the Module

Removing the Module

[Loading Film](#)

[Unloading Film](#)

[Introduction](#)

[Attaching the Camera Module](#)

[Removing the Film Cartridge](#)

[Changing Between 120 and 220 Film](#)

[Loading the Film Cartridge](#)

[The Camera Module Reset Button](#)

[Using the 120/220 Module](#)

[Unloading the Film](#)

[Removing the Camera Module](#)

[Introduction](#)

[Installation](#)

[Controls and Indicators](#)

[Keypad Controls](#)

[Loading Film](#)

[Threading film Through the Module Body](#)

[Loading Film into the Take-up Magazine](#)

[Unloading the Film](#)

[Using Standard 35mm Cassettes](#)

[Loading a 35mm Cassette](#)

[Unloading a 35mm Cassette](#)

[Other ManualsLib Projects](#)

**FEDERAL COMMUNICATIONS COMMISSION  
RADIO FREQUENCY INTERFERENCE STATEMENT**

**NOTE:** This equipment has been tested and found to comply with the limits for a Class A digital device, pursuant to Part 15 of the FCC Rules. These limits are designed to provide reasonable protection against harmful interference when the equipment is operated in a commercial environment. This equipment generates, uses, and can radiate radio frequency energy and, if not installed and used in accordance with the instruction manual, may cause harmful interference to radio communications. Operation of this equipment in a residential area is likely to cause harmful interference in which case the user will be required to correct the interference at his own expense.

**CAUTION:** Only computers and other peripheral devices which as a minimum comply with Class A limits should be used with this equipment. Shielded I/O cables should be used for equipment connections in order to ensure FCC emission limits are met. Any changes or modifications to this equipment not expressly approved by Agfa Division, Bayer Corporation, could void the user's authority to operate the equipment.

**CANADIAN RADIO INTERFERENCE  
REGULATIONS STATEMENT**

This digital apparatus does not exceed the Class A limits for radio noise emissions from digital apparatus set out in the Radio Interference Regulations of the Canadian Department of Communications.

Le présent appareil numérique n'émet pas de bruits radioélectriques dépassant les limites applicables aux appareils numériques (de la class A) prescrites dans le Règlement sur le brouillage radioélectrique édicté par le ministère des Communications du Canada.

# PCR II Plus

## *User Guide*

Part Number  
209649-002



Part Number 209649-002

**Note to Users**

Agfa Division, Bayer Corporation (also referred to as "Agfa") reviews all customer documentation and software for accuracy before shipment. Occasionally, in spite of precautions, the product you receive may differ somewhat from the customer documentation shipped to you. Generally, if such variations are known to exist and to significantly affect operation, a release note accompanies the documentation or software. If you receive such a note, be sure to read it before using the product

Copyright © 1994 by Bayer Corporation All rights reserved

No part of this publication may be reproduced, transmitted, transcribed, stored in a retrieval system, or translated into any language or computer language, in any form or by any means, whether electronic, mechanical, magnetic, optical, chemical, or manual, without prior written permission from Agfa Division, Bayer Corporation, 200 Ballardvale Street, Wilmington, Massachusetts 01887.

**Disclaimer**

This document was prepared by Customer Documentation, Agfa Division, Bayer Corporation. Illustrations are meant to be representative of, but not duplicates of, actual equipment and software. Agfa shall not be responsible for any errors or omissions. Please report any errors to Customer Documentation, Agfa Division, Bayer Corporation, 200 Ballardvale Street, Wilmington, Massachusetts 01887.

AGFA MAKES NO REPRESENTATIONS OR WARRANTIES WITH RESPECT TO THE CONTENTS OF THIS DOCUMENT OR THE SOFTWARE DESCRIBED IN THIS DOCUMENT, ITS QUALITY, OR PERFORMANCE, AND SPECIFICALLY DISCLAIMS ANY IMPLIED WARRANTIES OF MERCHANTABILITY OR FITNESS FOR ANY PARTICULAR PURPOSE. Agfa reserves the right to revise this document and to change the contents without any obligation to notify any person of such revision or changes.

**Trademarks**

AGFA and the Agfa rhombus are registered trademarks of Agfa-Gevaert N.V. Agfachrome and Optima are registered trademarks of Agfa-Gevaert AG. Conductor is a registered trademark and PCR II Plus is a trademark of Bayer Corporation. Apple and Macintosh are registered trademarks of Apple Computer, Inc. Ektachrome, Ektacolor, and Vencolor are registered trademarks of Eastman Kodak Co. IBM and PC are registered trademarks of International Business Machine Corporation.

Other brand or product names are trademarks or registered trademarks of their respective holders and have been used in an editorial fashion with no intention of infringement.

**Colophon**

The following typefaces appear in this document:

- Text..... Bookman
- Headings ..... Helvetica\* Bold
- Captions .... . . . Helvetica Light Oblique

\*Helvetica is a trademark of Linotype AG and/or its subsidiaries.

# Table of Contents

## Preface

Purpose.....	xiii
Audience.....	xlii
Overview .....	xiv

## Chapter 1 : Product Description

Introduction.....	1-1
Equipment and Supplies .....	1-2
PCR II Plus Accessory Kit.....	1-2
Professional Films.....	1-3
Color Densitometers .....	1-3
Camera Modules.....	1-4
Controls and Connectors.....	1-5
Front Panel.....	1-6
Rear Panel.....	1-8
Filter Correction and DAC Values.....	1-10

## Chapter 2: Installation

Introduction.....	2-1
Power Connection.....	2-2

Communication with Other Devices.....	2-4
Definitions of Communications Terms.....	2-4
Connecting to a GPIB Interface.....	2-5
Connecting to a SCSI Interface .....	2-6
Guidelines for SCSI Connection .....	2-6
SCSI Interface Single Device Configuration .....	2-7
SCSI Interface Multiple Device Configuration.....	2-7
Internal Termination.....	2-7
Changing Between GPIB and SCSI .....	2-9
Setting Device Addresses.....	2-10
Guidelines.....	2-10
Set Device Address Procedure .....	2-11
Selecting the Display Language .....	2-12
Film Backs and Film .....	2-13

### **Chapter 3: Start-up**

Introduction.....	3-1
Powering On the PCR II Plus.....	3-2
Warm-Up Period.....	3-2
Using the Front Panel Controls.....	3-3
Front Panel.....	3-3
The Ready Message.....	3-4

Function Selections.....	3-5
Resetting the PCRIIPlus.....	3-8
When Reset Occurs.....	3-8
Effects of Reset.....	3-9
Reset Defaults.....	3-10
The PCRIIPlus Beeper.....	3-10

## **Chapter 4: Film Control**

Introduction.....	4-1
Loading Film .....	4-2
Unloading Film.....	4-3
Advancing Film .....	4-4
Frame Count.....	4-5
Set Film Type .....	4-6
Specifying User Film Type.....	4-7
Currently Supported Film Types .....	4-7
Save LUT.....	4-8

## **Chapter 5: Image Control**

Introduction.....	5-1
Calibration Features.....	5-2
Calibration Functions .....	5-2

Pacing Control.....	5-3
Pacing Values and Imaging Speeds .....	5-3
Setting the Pacing Value .....	5-4
Guidelines for Selecting Pacing Values.....	5-4
Resolution Control .....	5-5

## **Chapter 6: Color Balance**

Introduction.....	6-1
Overview of the Process .....	6-2
Response Curves.....	6-3
Channels.....	6-4
Exposing Test Images.....	6-5
Brightness Control .....	6-6
Brightness Units.....	6-7
Setting Brightness .....	6-8
Contrast Control .....	6-9
Contrast Units.....	6-9
Setting Contrast Values .....	6-9
Repeats.....	6-10
When to Use Repeats .....	6-10
Increased Exposure .....	6-10
Repeats and Brightness .....	6-10
Setting the Repeat Value.....	6-10

Tips and Tricks .....	6-11
Film Guidelines .....	6-13
Changes and Default Settings.....	6-13
Dmax and Dmin .....	6-14
Increments and Channels .....	6-14
Trial and Error.....	6-14
Gauging the Effects of Changes.....	6-14
Off-Color    Slides.....	6-14
Guidelines for Print Film .....	6-15
Goal Density Tables.....	6-16
Slide Films.....	6-17
Print Films.....	6-18

## **Chapter 7: Troubleshooting**

Introduction.....	7-1
Status and Error Messages.....	7-2
Possible Problems and Solutions .....	7-4
Power Indicator Does Not Illuminate .....	7-4
PCRIIPlus Resets Suddenly.....	7-4
Computer Locks Up on Large Image Files.....	7-5
35mm Film Will Not Load .....	7-5
System Locks Up When You Touch Film Module.....	7-5

Calibration Errors .....	7-6
Calibration Out of Range .....	7-6
Reset Film Type .....	7-7
Reset Defaults .....	7-7
Battery Problems.....	7-8
Reloading Look Up Table Values .....	7-8
Resetting Filter Correction Values.....	7-8
Recurring Battery! Error Messages.....	7-9
Hardware Problems .....	7-10
Macintosh SCSI Interface Troubleshooting.....	7-10
General Image and Rasterization Problems .....	7-10

## Appendix

Technical Specifications .....	A-1
Input.....	A-1
Data Interface.....	A-1
File Formats.....	A-1
Film Formats.....	A-1
Supported Films.....	A-2
Addressability.....	A-2
Power Requirements.....	A-2
Physical.....	A-3
Environmental.....	A-3

EMI/RFI.....	A-3
Safety Standards.....	A-3
Theory of Operation.....	A-4
User Log Tables.....	A-5
Glossary.....	A-9
Primary and Secondary Error Codes.....	A-13
Code 83: Illegal Command Byte .....	A-13
Code 84: Illegal Data Byte.....	A-13
Code 91: Memory Error .....	A-15
Code 92 (PC): GPIB Interface Error .....	A-16
Code 92 (Macintosh): SCSI Interface Error.....	JV-16
Code 93: CRT Brightness or Contrast Calibration Error .....	A-16
Code A1: Module Error .....	A-17

## **Index**

## **Camera Modules**

# Preface

# Purpose

This guide describes how to operate the PCR II Plus film recorder.

The PCR II Plus film recorder is designed to meet the requirements of many applications, including presentation graphics, commercial mini-lab operations, scientific visualization, and graphic arts.

Imaging systems that support the PCR II Plus film recorder can be made up of many different combinations of hardware and software. To use your film recorder most effectively, you need to understand all the components of your unique imaging system.

# Audience

This manual is written for operators who will use the PCR II Plus film recorder regularly as a production tool. It assumes that these operators are familiar with the following:

- Basic concepts of color photography.
- Operation of the front end computer.
- Operation of the programs in use on the front end computer.
- Operation of rasterizers or direct driver software programs that support the PCR II Plus.
- Use of a densitometer.

This basic knowledge is critical to the effective and successful operation of this film recorder.

# Overview

The contents of this guide are summarized below.

## *Chapter 1: Product Description*

Features and parts of the PCR II Plus film recorder.

## *Chapter 2: Installation*

System requirements, power connections, communication interface between the PCR II Plus and your front end.

## *Chapter 3: Start-up*

Starting up the PCR II Plus and using the controls on front and rear panels.

## *Chapter 4: Film Control*

Loading, advancing, rewinding and other film handling functions.

## *Chapter 5: Image Control*

Calibration features, pacing speed control, resolution control, and exposing test images.

## *Chapter 6: Color Balance*

Procedures used to run test images, evaluate them, and adjust brightness, contrast, and repeat values to achieve optimum output.

## *Chapter 7: Troubleshooting*

Definitions of status and error messages that appear in the control panel message window and procedures to clear the error messages.

## *Appendix*

Technical specifications, theory of operation, sample and blank forms for keeping logs on PCR II Plus operation. Also includes a glossary of terms commonly used with PCR II Plus operation and information about primary and secondary error codes.

## *Index*

Enables quick look-up of specific topics.

### *Camera Modules*

Contains a description of the 35mm camera module that is standard equipment for the PCR II Plus. If you purchase additional camera modules, you receive corresponding documentation that may be added to this manual following the 35mm camera module description.

Chapter 1 :  
**Product Description**

# Introduction

This chapter describes the PCR II Plus product and its accessories.

- Required Equipment and Supplies
- Controls and Connectors

# Equipment and Supplies

Here are the basics you need to operate your PCR II Plus film recorder:

- PCR II Plus film recorder.
- PCR II Plus Accessory kit.
- Professional film type supported by the film recorder.
- Color densitometer, transmissive for film, reflective for prints.
- Graph paper, copies of the form in the Appendix, or spreadsheet software.
- Compatible camera module.

## PCR II Plus Accessory Kit

Verify that your accessory kit contains the following components:

- Power cord (both 120 And 220 volt types)
- Camera back (if ordered)
- Warranty statement
- Product registration card

You will need each of these to complete the installation of your new film recorder. Contact your dealer if any of the components are missing.

After unpacking the PCR II Plus, fill in and submit the product registration card. Save the carton and all other packaging materials in case future off-site upgrading or service are required.

## Professional Films

For best results, use professional films in your PCR II Plus. These films have more stringent tolerances for color balance and ASA ratings.

The PCR II Plus supports these professional films:

- Agfachrome® 100 RS Plus
- Agfa Optima® 125
- Kodak® Vericolor® III Type S
- Ektachrome® 100 Professional (EPN).

**Note:** Using print film requires establishing a baseline before color balancing the PCR II Plus. If you use print film, see the section *Guidelines for Using Print Film* in Chapter 6 before color balancing the system.

## Color Densitometers

Use a densitometer to take readings of your processed film or prints. If you do not own a densitometer, arrange with your processing lab to take the readings.

## Camera Modules

The PCR II Plus is designed for operation with these camera modules:

- Agfa PCR II Plus 35mm module (standard).

**Note:** Use only the 35mm module that is designed for the PCR II Plus.

- Agfa PCR II Plus 35mm bulk loading module with capacity for 100 feet (30.48 m) of film.
- Agfa PCR II Plus medium format module (uses 120/220 film).
- Agfa PCR II Plus 4x5 module.

# Controls and Connectors

This section describes the PCR II Plus controls and connectors. Learn their location and function before you attempt to install or operate your film recorder.

Figure 1.1 shows the location of the PCR II Plus controls and connectors.

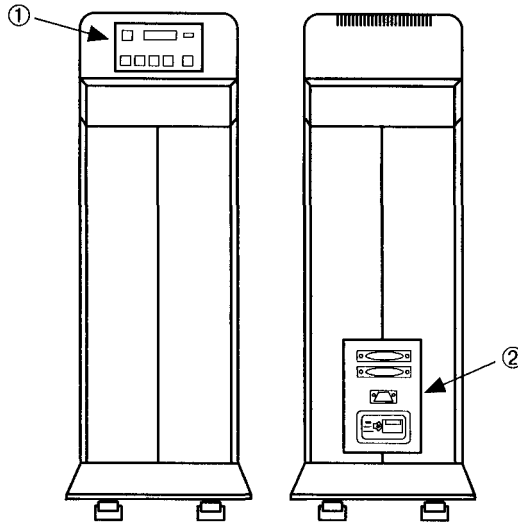

*Figure 1 1 Orientation of Controls and Connectors*

*Left, front view Right, rear view*

*①-Operator controls ②-Power and signal input panel*

## Front Panel

The PCR II Plus front panel provides access to the features and information that you need to operate the film recorder.

Figure 1.2 shows a top view of the PCR II Plus. A key to the numbered items appears on page 1-7.

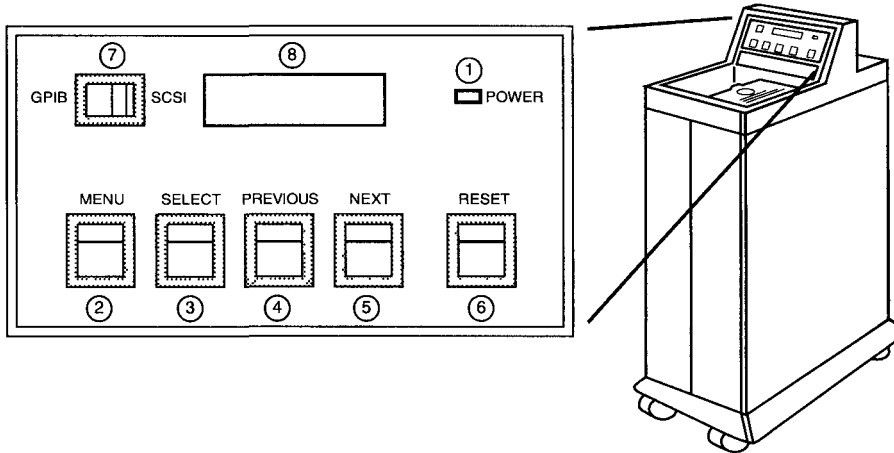

Figure 1.2. Front Panel

- ① POWER Indicator  
This green indicator illuminates when you turn on the film recorder.
- ② MENU Button  
Press to access the PCR II Plus user menu.
- ③ SELECT  
Activates the function displayed in the message window.
- ④ PREVIOUS  
Scrolls backward through the displayed menu or submenu.
- ⑤ NEXT  
Scrolls forward through the displayed menu.
- ⑥ RESET  
Resets all the functions of the PCR II PLUS. Use this if a fault condition causes the film recorder to cease operation.
- ⑦ GPIB/SCSI Switch  
Enables you to select either GPIB or SCSI operation, depending on the type of host computer you are using to output images.
- ⑧ MESSAGE WINDOW  
16-digit, 2-line LCD (liquid crystal display). Status and error messages appear in this window.

# Rear Panel

Figure 1.3 shows the PCR II Plus rear panel. A key to the numbered items appears on page 1-9.

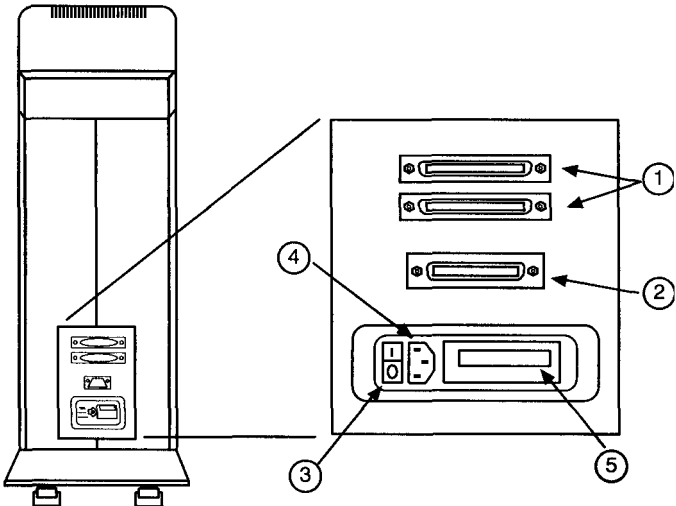

Figure 1.3. Rear Panel Switch and Connector Identification

- ① **SCSI Interface Ports**  
These accept SCSI computer interface cables for transmitting data and commands to the PCR II Plus. Use these ports to connect the film recorder to a Macintosh or other device that uses the SCSI protocol.
  
- ②  **GPIB Interface Port**  
Accepts the IEEE-488 computer interface cable for transmitting data and commands to the PCR II Plus. Use this port if your host computer supplies GPIB output.
  
- ③ **Power Switch**  
Turns the film recorder on and off.
  
- ④ **Socket**  
Input connector for the power cord.
  
- ⑤ **Fuse**  
Protects the film recorder's electrical systems by breaking the circuit when the current exceeds the rated value. The fuse value is stamped on the serial number tag.

# Filter Correction and DAC Values

Your PCR II Plus is preset with a unique set of color filter correction and digital to analog converter (DAC) values.

- Filter correction values adjust the brightness and contrast settings to compensate for variations in each filter (red, blue, and green).
- DAC values are used by the PCR II Plus operating software.

The filter correction and DAC values are stored in the film recorder's memory. The unique set of values for your PCR II Plus are recorded on a label on the back panel. See Figure 1.3.

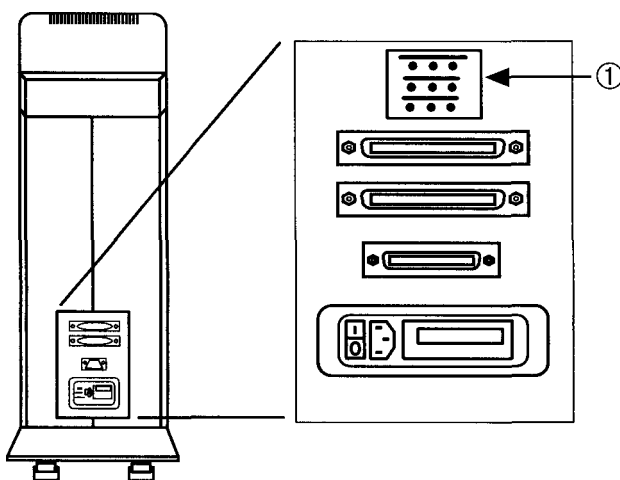

Figure 1.3. The color filter correction and DAC values are recorded on a label (①) on the PCR II Plus back panel.

A battery failure could cause the color filter correction and DAC values to be lost from memory. Procedures to restore filter correction values are described in the sections *Resetting Filter Correction Values* in chapter 7.

Chapter 2:  
**Installation**

# Introduction

This chapter describes how to install your PCR II Plus and prepare it for use. It includes the following:

- Connecting the power cable.
- Connecting the PCR II Plus to host computers that use GPIB communication.
- Connecting the PCR II Plus to host computers that use SCSI communication.
- Switching the PCR II Plus between GPIB and SCSI communication.
- How to select the language used by the control panel message display window.
- A list of the different film backs you can use with the PCR II Plus.

Read all the installation instructions carefully before you plug in your PCR II Plus. Follow all the caution and warning messages in these instructions. Keep this manual handy for reference.

# Power Connection

To connect the PCR II Plus power cord:

- Step 1: Make sure that the wall current matches the power specifications stated on the film recorder's serial number tag. See Figure 2.1.

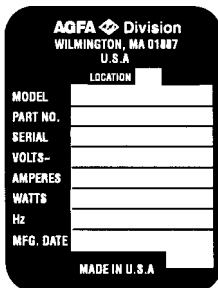

Figure 2.1. Serial Number Tag

- Step 2: Make sure that the PCR II Plus power switch is in the OFF position. The power switch is located on the rear panel. See Figure 2.2.
- Step 3: Connect the female end of the power cord supplied with the film recorder to the three-pronged socket on the rear panel. See Figure 2.2.

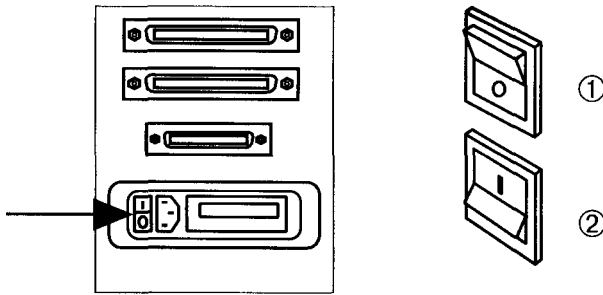

Figure 2.2. Left, location of power switch.

Right: Ⓜ Power switch in the off position. Ⓞ Power switch in the on position.

**Step 4: Plug the three-pronged male end into a standard grounding-type power socket.**

**WARNING:**

**PCR II Plus is electrically grounded, and its power connector will fit only a grounding-type AC outlet. This is a safety feature. If you cannot insert the plug into the outlet, contact a licensed electrician to install a properly grounded outlet.**

# Communication with Other Devices

The following list gives a brief overview of the procedure to set up your PCR II Plus to communicate with the host computer and peripheral devices.

1. Connect the communication cables. See the sections *Connecting to a GPIB Interface* and *Connecting to a SCSI Interface* in this chapter.
2. Specify which communication protocol you are using. See the section *Changing Between SCSI and GPIB* in this chapter.
3. Set the PCR II Plus internal terminator correctly. See the section *Internal Termination* in this chapter.
4. Set the PCR II Plus device address correctly. See the section *Setting Device Addresses* in this chapter.

## Definitions of Communications Terms

PCR II Plus is a *target* device. This means that it is a destination for both commands and image data that the host computer sends to it.

The PCR II Plus connected to the host computer form a *chain*. This is a series of devices linked together with communication cables. Chains may include external hard drives, CD ROM readers, etc. This series of linked devices may also be referred to as a *daisy chain*, or, if the system uses SCSI communication, a *SCSI chain*.

There are two different communication protocols that the PCR II Plus can use:

1. GPIB—General Purpose Interface Bus; also known as IEEE 488-1978 interface.
2. SCSI—Small Computer Systems Interface.

Both are widely recognized data communications interfaces for high-speed transmission of data from one device to another.

# Connecting to a GPIB Interface

Connect the PCR II Plus to devices that use the GPIB communication protocol as shown in Figure 2.3. Either end of the GPIB cable can be connected to the film recorder.

**Caution:**

Make sure that your host computer and film recorder are turned off when you attach the cables.

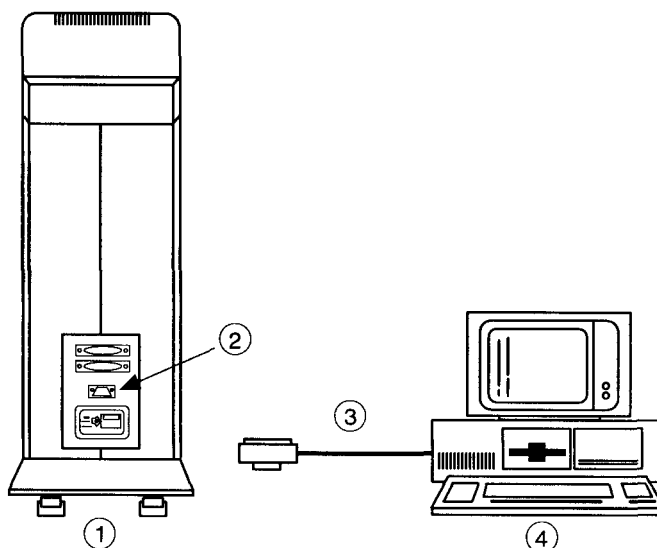

Figure 2 3 GPIB interface connection for an IBM PC-type host  
①-PCR II Plus, rear view ②-GPIB port  
③-GPIB interface cable ④-IBM PC-type host computer

**Note:** Systems using GPIB communication exclusively do not require termination.

# Connecting to a SCSI Interface

This section describes how to connect the PCR II Plus to devices that use SCSI communication.

You need the appropriate SCSI cables to complete the installation. These cables may be supplied with peripheral devices, or may be purchased separately.

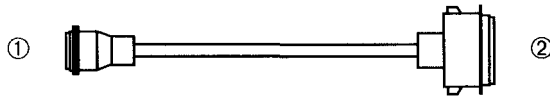

Figure 2 4 SCSI system cable ①—25 pin plug ②—50 pin plug  
Used to connect the Macintosh SCSI port to the film recorder or other SCSI device

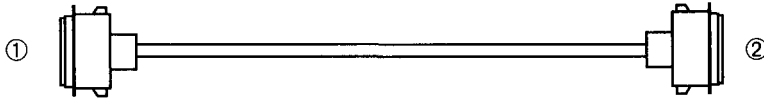

Figure 2 5 SCSI cable extender ①—50 pin socket ②—50 pin plug  
Connects to a terminator or a SCSI cable from another peripheral device

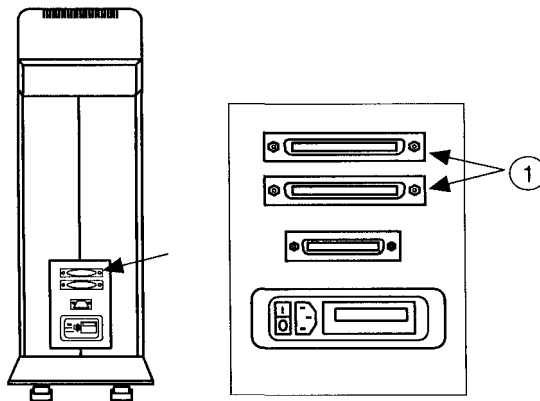

Figure 2 6 There are two SCSI ports on the PCR II Plus rear panel  
On the PCR II Plus, as on other SCSI devices, these two ports are interchangeable

## Guidelines for SCSI Connection

**Caution:**

Turn off the host computer and the film recorder before you connect or disconnect the SCSI cables.

- The total length of SCSI cable across the entire chain should be 15 feet (4.57 meters) or less. When measuring this maximum length, include all internal SCSI cables in the host computer and peripheral devices.
- Make sure that both ends of a SCSI chain are terminated. See the section *Internal Termination* in this chapter.
- Fasten the interlocking wire clips or screws on the ends of all SCSI cables. Provide adequate strain relief wherever cables connect into the devices.
- You can connect the SCSI cable to either SCSI port on the PCR II Plus rear panel.

## SCSI Interface Single Device Configuration

Connect the SCSI cable to either SCSI interface connector on the PCR II Plus. You can also add the cable extender (item ③ in Figure 2.7) if you need a longer cable to reach from the Macintosh to the film recorder.

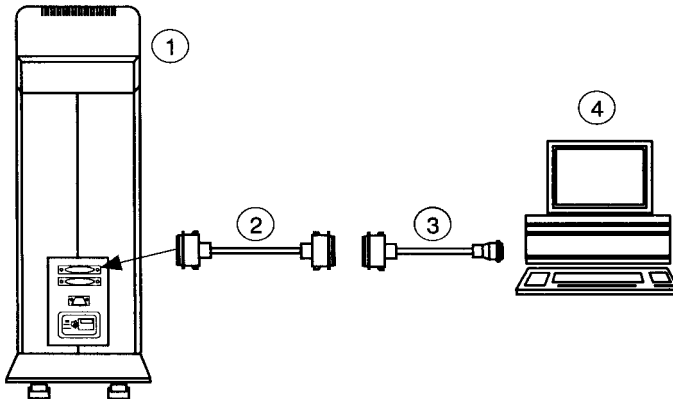

*Figure 2.7. Single device setup. Both the PCR II Plus and the host computer are terminated internally*

- ①-SCSI ports. ②-PCR II Plus with internal termination on.  
③-Cable extender. ④-SCSI system cable. ⑤-Macintosh host computer.

## SCSI Interface Multiple Device Configuration

Peripheral devices, such as the PCR II Plus film recorder, have two SCSI ports. These ports are used for terminators, incoming data, and outgoing data and can be used interchangeably. See Figures 2.8 and 2.9.

The PCR II Plus can be internally terminated. The film recorder's position in the SCSI chain determines whether you should turn internal termination on or off:

- At the end of the chain, turn on internal termination.
- Anywhere else on the chain, turn off internal termination.

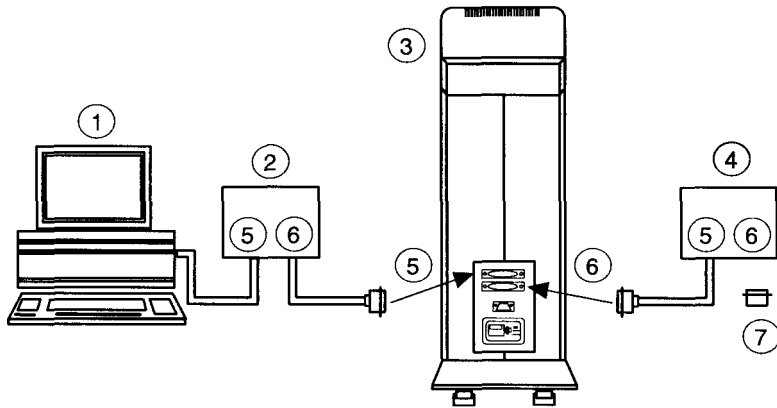

Figure 2 8 Multiple device setup with the PCR II Plus in the middle of the chain  
 ①-Macintosh host computer, terminated Internally ②-SCSI peripheral device A  
 ③-PCR II Plus with internal termination off  
 ④-SCSI peripheral device B ⑤-SCSI interface in ⑥-SCSI interface out  
 ⑦-Terminator for the end of the SCSI chain Not required if this device can be internally terminated

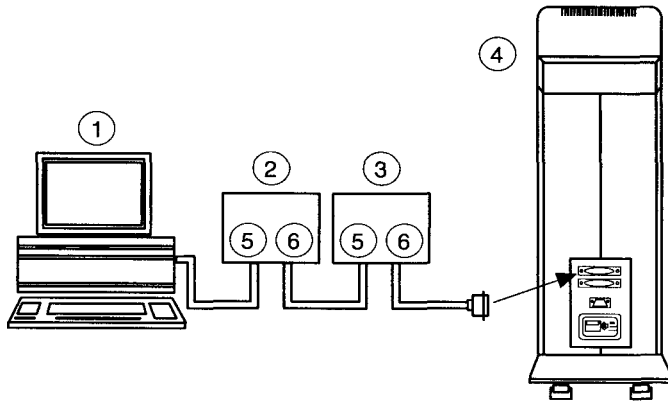

Figure 2 9 Multiple device setup with the PCR II Plus at the end of the chain  
 ①-Macintosh host computer, terminated Internally  
 ②-SCSI peripheral device A ③-SCSI peripheral device B  
 ④-PCR II Plus with internal termination on  
 ⑤-SCSI interface in ⑥-SCSI interface out

## Internal Termination

If you use SCSI communication, you need to terminate both ends of the SCSI chain.

- The PCR II Plus contains an internal terminator that you can turn on and off from the control panel.
- When the internal terminator is off, the PCR II Plus can be installed anywhere on the SCSI chain to any host computer.
- When the PCR II Plus is installed at the end of a SCSI chain, the internal terminator must be on.

Follow this procedure to turn internal termination on or off:

Step 1: Press MENU once, then NEXT or PREVIOUS until the message window displays either DISABLE SCSITERM (internal SCSI terminator is on) or ENABLE SCSITERM (internal SCSI terminator is off).

Step 2: Press SELECT. This changes the termination setting and the message displayed in the message window.

Step 3: Press MENU to return to the ready menu.

# Changing Between GPIB and SCSI

Use the GPIB/SCSI switch on the PCR II Plus front panel to select either GPIB or SCSI operation.

Step 1: Determine which communication protocol your computer system uses. Typically:

- PCs and PC compatibles use GPIB.
- Macintosh computers use SCSI.

However:

- PC and PC compatible computers can be equipped with a board that enables them to use SCSI communication.
- Macintosh computers can be equipped with a board that enables them to use GPIB communication.

Step 2: Move the switch on the control panel to the correct position. The settings are labeled.

- If you change the GPIB/SCSI setting while the film recorder is in READY mode, it resets the device.
- If any other menu selection is displayed when you change the GPIB/SCSI setting, press RESET to reset the interface.
- If you change the position of the GPIB/SCSI switch when the film recorder is off, the PCR II Plus uses the new communication protocol the next time you start it.

# Setting Device Addresses

Each device on the chain is assigned a unique address that specifies a location or destination of information.

Use the controls and message window on the PCR II Plus front panel to set the film recorder's device address.

## Guidelines

Before you set the PCR II Plus device address, note these guidelines:

- The default SCSI ID setting is one (1).
- The default GPIB address is two (2).
- When using GPIB communication between your host computer and the PCR II Plus, the GPIB address must be an even number.
- When setting the SCSI address, you can choose an address between zero (0) and six (6). If you are connecting to a Macintosh, do not set the PCR II Plus address to 0. This SCSI device address is reserved for the hard drive and CPU of the Macintosh.
- Know the addresses of all the other devices on your chain. Do not assign a previously used address to the PCR II Plus.

## Set Device Address Procedure

To set the device address, use the front panel controls to access the device address function.

Follow this procedure to set the address:

- Step 1: Make sure that the PCR II Plus is ON and ready and that you know the device addresses of all other peripherals being used on the chain with your film recorder.
- Step 2: Press MENU once, then NEXT or PREVIOUS until the message window displays SET GPIB ADDRESS or SET SCSI ADDRESS. The selection that appears depends on the current communication mode.
- Step 3: Press SELECT once. The message window displays the current device address (e.g., GPIB 2 or SCSI 1).
- Step 4: To change the address setting, press NEXT or PREVIOUS until the message window displays the address you want to use.
  - If you are using SCSI communication, you can select a number from 1 to 6 for the address.
  - If you are using GPIB communication, you can select an even number from 2 to 30 for the address.
- Step 5: Press SELECT to choose the new address.
- Step 6: Press MENU to return to the ready menu.

## Selecting the Display Language

This function enables you to choose the language used to display messages on the PCR II Plus. Your choices are English, German, or French.

To select the display language:

- Step 1: Press MENU once.
- Step 2: Press PREVIOUS or NEXT until the message window displays SELECT LANGUAGE SELECT FUNCTION. Press SELECT.
- Step 3: Press PREVIOUS or NEXT to scroll through the selections ENGLISH SELECT LANGUAGE, GERMAN SELECT LANGUAGE, and FRENCH SELECT LANGUAGE.
- Step 4: Press SELECT when the window displays the language you need to use. The display returns to the main menu.
- Step 5: Press MENU to return to the main ready menu.

# Film Backs and Film

The PCR II Plus can accommodate the following camera backs:

- 35-mm 36 exposure
- 35-mm bulk (holds 100'/30.48 m rolls of 35mm film)
- Medium format camera (120/220 film)
- Single-sheet 4x5 module

## Chapter 3: Start-up

# Introduction

This chapter presents information about:

- Powering on and warming up the PCR II Plus.
- User controls on the front and rear panels.
- Resetting the PCR II Plus.
- Resetting defaults.
- Guidelines for basic use.

# Powering On the PCR II Plus

- Step 1: Find the power switch on the rear panel.
- Step 2: Press the side of the switch labeled I to turn on the PCR II Plus. The green power indicator on the film recorder front panel lights up when the device is on.
- Step 3: After you turn on the PCR II Plus, the message window displays a series of messages as it runs:
- A diagnostic test to check its internal circuits. This takes a few seconds.
  - A warm up routine. This takes about two minutes.
  - A calibration sequence to evaluate and adjust the CRT brightness levels. This takes about thirty seconds;
- Step 4: Let the PCR II Plus warm up for 30 minutes before you image a job. See the section *Warm-Up Period* on page 3-3 for more information.

**Note:** The PCR II Plus periodically calibrates on its own. This is a normal operation that ensures the proper functioning of the unit and does not interfere with the imaging process.

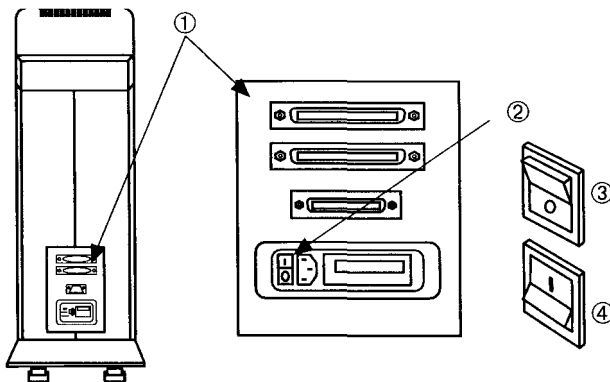

Figure 3.1. Location of the power switch.

①-Rear panel. ②-Power switch. ③-Off position. ④-On position.

## Warm-Up Period

Let the PCR II Plus warm up for thirty minutes after you turn on the power. It is possible to record images as soon as the calibration sequence is complete, but the full warm-up period ensures optimal image quality.

**Note:** The warm-up calibration sequence does not replace the need to color balance the system. For procedures, see Chapter 6.

Follow these guidelines regarding the warm-up period:

- If the film recorder has been turned off for several hours, let it warm up for thirty minutes before you begin recording images.
- If you have been using the film recorder for several hours and turn it off for a few minutes, you do not have to wait thirty minutes when you turn on the unit again.
- If you experience brown-out or power surge conditions, turn the film recorder off. Severe line voltage fluctuations can damage the power supplies and internal circuits. When you restart the film recorder after a brown-out or surge condition clears, let it warm up for thirty minutes.
- Never turn the film recorder on-off-on in rapid sequence. This can damage the equipment. Allow at least ten seconds between on-off cycles.

# Using the Front Panel Controls

This section explains how to use the PCR II Plus front panel switches and display to select the pacing and repeat values, shoot test patterns, set the device address and optimize the color balance of your film output.

## Front Panel

The PCR II Plus uses a 16-character, 2-line LCD message window to display status and error codes. There are four control buttons on the front panel—MENU, SELECT, PREVIOUS and NEXT. These enable you to scroll through the film recorder's user menus and select among a wide range of setup parameters and test routines. You can switch between GPIB and SCSI operation using a single front panel switch. The reset button is also located on this front panel (see Figure 3.2).

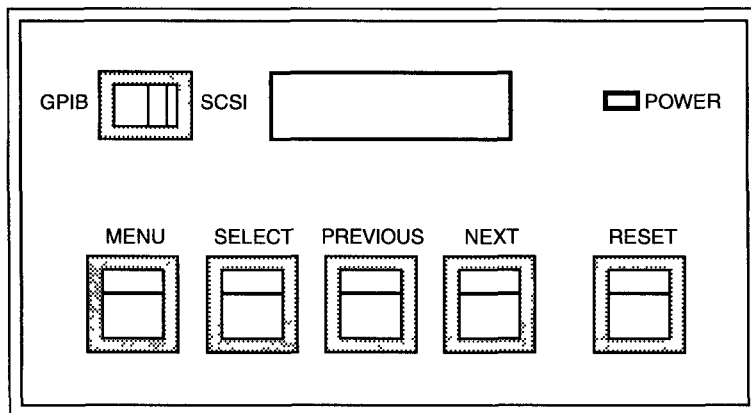

Figure 3.2. PCR II Plus Control Panel

## The *Ready* Message

When the PCR II Plus finishes its warm-up cycle, the message window displays a "ready" message that indicates the imaging mode (2K or 4K), the type of film currently selected, and the frame number.

- Press MENU once to enter the user menu.
- Press either PREVIOUS or NEXT to scroll through the user menu.
- Press SELECT to access or activate the currently displayed function. This either executes a command immediately or displays a submenu offering further choices.
- Press PREVIOUS or NEXT to scroll through submenus.
- Press MENU again to return to the ready menu.

# Function Selections

This section lists and defines the selections in the user menu.

**Note:** Each time you access PCR II Plus function menus, the LCD display starts with the last selected function. This makes it easier to change prior settings without scrolling through the entire menu set.

## **READY**

### **AG100PLS 4K1**

Identifies the film type, imaging resolution mode and frame number.

## **LOAD FILM**

### **SELECT FUNCTION**

Advances a new roll of film and resets the frame counter to # 1.

## **UNLOAD FILM**

### **SELECT FUNCTION**

Resets the frame to counter #0.

## **ADVANCE FILM**

### **SELECT FUNCTION**

Advances the film one or more frames.

## **SET FRAME COUNT #**

### **SELECT FUNCTION**

Enables you to set the frame counter to any number between 0 and 255 without advancing the film.

## **SET FILM TYPE**

### **SELECT FUNCTION**

Enables you to select one of the supported film types or the USER FILM compensation values for a specific module. When you make a selection, the PCR II Plus loads the appropriate compensation values and performs a calibration.

**RESET DEFAULTS****SELECT FUNCTION**

Reloads the default brightness, contrast and repeat values for the currently selected film type.

**SAVE LUT****SELECT FUNCTION**

Transfers the look-up table currently active in the PCR II Plus into the default memory location for the installed camera module and film type.

**SET PACING****SELECT FUNCTION**

Enables you to adjust imaging speed to better match rasterizer data transfer rates. See the section *Pacing Control* in Chapter 5 for more information.

**SET GPIB ADDRESS****SELECT FUNCTION**

Sets the GPIB device address.

**SET SCSI ADDRESS****SELECT FUNCTION**

Sets the SCSI device address.

**SET BRIGHTNESS****SELECT FUNCTION**

Opens a submenu that enables you to view and/or change the brightness value for each of the three colors. Changes to brightness values become the defaults for the selected film type until you reset the defaults. See the section *Brightness Control* in Chapter 6 for more information.

**SET CONTRAST****SELECT FUNCTION**

Opens a submenu that enables you to view and/or change the contrast value for each of the three colors. Changes to contrast values become the defaults for the selected film type. See the section *Contrast Control* in Chapter 6 for more information.

**SET RESOLUTION****SELECT FUNCTION**

Enables you to set 4K (default) or 2K addressability.

**SET REPEAT VALUE****SELECT FUNCTION**

Enables you to repeat a color pass multiple times on the CRT to compensate for lower speed films. Changes to repeat values become the defaults for the selected film type.

**TEST IMAGE****SELECT FUNCTION**

The TEST IMAGE submenu contains test images that you can use to verify proper functioning of your PCR II Plus.

**SELECT LANGUAGE****SELECT FUNCTION**

Enables you to select the language used by the control panel message window. Choices are English, German, or French.

**CRT CALIBRATION****SELECT FUNCTION**

Calibrates the internal brightness levels of the film recorder.

**DISABLE SCSI TERM****SELECT FUNCTION**

Turns off the internal terminator.

**ENABLE SCSI TERM****SELECT FUNCTION**

Turns on the internal terminator.

**DISABLE CAL****SELECT FUNCTION**

Turns off the calibration routine.

**ENABLE CAL****SELECT FUNCTION**

Turns on the calibration routine.

# Resetting the PCR II Plus

Reset PCR II Plus if an error condition causes it to cease operating properly. Press the RESET switch on the front panel.

## When Reset Occurs

The system resets:

- During power-up.
- When you press the reset switch on the front panel. This is a warm reset.
- When the film recorder receives reset command from the host computer through the SCSI or GPIB communication interface.
- After you change the position of the GPIB/SCSI switch and the READY message is displayed in the message window.
- After the camera module cable is connected or disconnected.
- After the PCR II Plus receives a Select Resolution with Reset command.

## Effects of Reset

During system reset, the PCR II Plus performs the following:

- Executes a warm-up.
- Tests the system memory.
- Executes a system reset.
- Calibrates assigned brightness levels.
- Programs the address specified in PCR II Plus memory into the GPIB or SCSI controller.
- Rotates the filter wheel to the dark filter position.
- Loads default image dimensions for the camera module currently in use. If a no camera module is attached, NO MODULE appears in the message window.
- Clears an end-of-film condition, if one exists.
- Interrupts the current command in progress.
- Sounds a half second beep.

The PCR II Plus requires several seconds to complete a system reset.

Wait until the READY message appears before you send data from the host computer. If you send data before the PCR II Plus is ready, the reset operation hangs up. To recover, reset the system.

# Reset Defaults

This function restores the factory-set default look-up table, brightness, contrast and repeat values for the currently selected film type. Any customized values previously stored for this film type are replaced by the default settings.

## The PCR II Plus Beeper

The PCR II Plus emits various sounds to indicate different operating conditions. The following list describes these sounds and their meanings:

- **Solid one-half second beep:** Completion of a reset.
- **Four short beeps:** The PCR II Plus has successfully recorded an image.
- **Single short beep:** With an END OF FILM message on the front panel display, indicates that the PCR II Plus is out of film. Repeats approximately once every five seconds.
- **Two-second warbled beep:** Indicates an error. Repeats approximately every five seconds. The alarm stops when you reset the film recorder. SRQ is serviced from the host (GPIB version) or a REQUEST SENSE command is sent from the initiator or host (SCSI version).

Chapter 4:  
**Film Control**

# Introduction

This chapter describes functions used in the following:

- Load and unload film.
- Advance film.
- Frame count.
- Set film type.
- Optimize film use.

# Loading Film

After you load film into the 35mm camera module, follow this procedure to execute a LOAD FILM command:

Step 1: Press MENU once, then press PREVIOUS or NEXT until the message window displays LOAD FILM SELECT FUNCTION.

**Note:** The LOAD FILM command appears only after you have selected the UNLOAD FILM function.

Step 2: Press SELECT to execute the LOAD FILM command. This command does the following:

- Advances the film to position # 1.
- Resets the PCR II Plus frame counter to one (#1).
- Clears the end-of-film condition.

Step 3: Press MENU once to return to the ready condition.

Procedures for inserting film into a camera back are described in the camera module sections at the end of this guide.

# Unloading Film

Before you remove an exposed roll of film from the 35mm camera module, follow this procedure to execute an UNLOAD FILM command:

Step 1: Press MENU once, then press PREVIOUS or NEXT until the message window displays UNLOAD FILM SELECT FUNCTION.

**Note:** The UNLOAD FILM command appears only after you have selected the LOAD FILM function.

Step 2: Press SELECT to execute the UNLOAD FILM command. This resets the frame counter to zero (#0).

Step 3: Rewind the film using the instructions in the corresponding camera module section.

Step 4: Open the camera back and remove the used film. For procedures, refer to the section on the corresponding camera module.

Step 5: Press MENU once to return to the ready condition.

# Advancing Film

The ADVANCE FILM command advances the film without making an exposure. Use it to separate jobs with unexposed frames.

Follow this procedure:

- Step 1: Press MENU once, then PREVIOUS or NEXT until you reach the ADVANCE FILM selection.
- Step 2: Press SELECT. The film advances one frame and the frame counter increments by one. This is repeated each time you press SELECT under ADVANCE FILM.
- Step 3: Press MENU once to return to the ready condition.

# Frame Count

The SET FRAME COUNT # command sets the frame number that appears in the READY message in the message window. You can set the frame number to any value between zero and 255. This function does not advance the film in the 35mm module.

Use this command if you forget to execute the LOAD FILM function or the frame number in the message window does not match the actual frame that the camera is ready to expose.

Follow this procedure:

- Step 1: Press MENU once then PREVIOUS or NEXT until you reach the SET FRAME COUNT# selection.
- Step 2: Press SELECT to display the frame count submenu. The display reads FRAME# nnn, where nnn is some number between zero and 255.
- Step 3: Press NEXT to reach the desired number. Select 1 or greater for the counter to begin recording the number of frames that you have imaged.
- Step 4: Press SELECT to choose your frame number and exit the frame counter submenu.
- Step 5: Press MENU to return to the ready condition.

# Set Film Type

The SET FILM TYPE function enables you to specify which type of film you are using.

To use this function, follow these steps:

- Step 1: Attach the camera module to the film recorder.
- Step 2: Press MENU once, then NEXT or PREVIOUS until the display reads SET FILM TYPE SELECT FUNCTION.
- Step 3: Press SELECT. The message window displays the currently selected film type.
- Step 4: Press NEXT or PREVIOUS to scroll through a list of the other supported film types. For example, if you are using the 35mm module, your choices are:
  - EKTA ASA 100 PRO
  - AGFA RS100 PLUS
  - AGFA OPTIMA 125
  - VERICOLOR 3S
  - USER FILM 1
  - USER FILM 2
- Step 5: When the message window displays the film type you are using, press SELECT. The film recorder does the following:
  - Loads the default look-up table for the specified film type.
  - Loads the brightness, contrast and repeat values last set at the front panel controls for the specified film type.
  - Calibrates the CRT brightness levels.
- Step 6: Press MENU to return to the READY message.

## Specifying User Film Type

Two USER FILM TYPE selections are available for each camera module. Use these selections to store your own customized look up table and brightness, contrast, and repeat values.

When you use the SET FILM TYPE command to specify USER FILM TYPE, the PCR II Plus calibrates the CRT brightness levels using your customized brightness and contrast values. If one of your custom values exceeds the PCR II Plus limitations, a calibration error occurs. In this case, you need to specify new brightness or contrast values and reset the film recorder.

**Note:** Repeated calibration errors can indicate a hardware problem.

## Currently Supported Film Types

Table 3.1 lists the film types that the PCR II Plus currently supports. The three columns show:

1. The abbreviated name that appears in the display window.
2. The film type that corresponds to the abbreviation.
3. The designated internal film number (required for direct programming and for certain rasterizer applications).

Abbreviated Name	Film Type	Number
AGFA RS100 PLUS	Agfachrome RS100 Plus Professional	6
AGFA OPTIMA 125	Agfa Optima 125	9
EKTA ISO100 PRO	Ektachrome 100 Professional EPN	1
VERICOLOR 3S	Vericolor Type III S	10
USER FILM 1	Custom film type	16
USER FILM 2	Custom film type	17

*Table 3.1. Supported film types.  
These are supported by all PCR II Plus camera modules.*

# Save LUT

This function transfers the look-up table currently active in the PCR II Plus into the default memory location for the installed camera module and film type. This feature enables you to:

- Substitute new look-up table values for the standard film types.
- Customize and save complete compensation values for a film not supported by the PCR II Plus.

For example, use this function if you want to use a 35mm film type not supported by the PCR II Plus.

1. Install the 35mm module.
2. Select either USER FILM TYPE 1 or USER FILM TYPE 2.
3. Download a new look up table from your host computer.
4. You can fine tune brightness, contrast and repeat settings and save them in this location.

**Note:** There are two user memory locations allocated for each type of camera module. Each time you use SAVE LUT, you write over your first set of stored values. To protect your data, keep a written record of the look up tables, brightness, contrast, and repeat values that you use.

Chapter 5:  
**Image Control**

# Introduction

This chapter describes how to control the quality of the images by setting the following on the PCR II Plus:

- Calibration features.
- Pacing control.
- Resolution control.

# Calibration Features

The PCR II Plus calibrates itself to ensure that its CRT brightness and contrast levels remain consistent throughout the day.

The film recorder calibrates:

- At the end of the warm-up sequence.
- Each time you remove and replace the camera back.
- Each time you select a new film type.

The PCR II Plus also calibrates periodically during routine imaging unless you select the **DISABLE CAL** function to disable the automatic calibration.

## Calibration Functions

There are three calibration functions:

1. **CRT CALIBRATION** forces the PCR II Plus to calibrate all of its assigned brightness and contrast levels. Use this function to clear a brightness or contrast calibration error message.
2. **DISABLE CAL** shuts off the PCR II Plus calibration routine. The film recorder will not calibrate even when a command to force a calibration is sent from the host computer.

**Note:** In normal operations, leave calibration on. However, there may be certain imaging applications where it may be easier to work with calibration shut off.

3. **ENABLE CAL** turns on the calibration routine if you had previously disabled it.

# Pacing Control

The pacing control enables you to adjust the film recorder so that its imaging speed matches the rate of data flowing from the rasterizer.

The PCR II Plus can record 4K images in just over one minute. Some rasterizers may take longer than this to send complex image files to the film recorder. When this occurs, the PCR II Plus pauses when it has imaged all available data and resumes imaging when the rasterizer sends more data. An interrupted or uneven flow of data from the rasterizer can cause artifacts on the recorded images. Regulating the imaging speed can improve image quality.

## Pacing Values and Imaging Speeds

Select SET PACING from the function menu to display the pacing value.

You can specify pacing values from 3 to 255. Lower numbers mean faster imaging; higher numbers mean slower imaging.

PACING HS (High Speed) indicates the highest speed for the PCR II Plus. This is the default setting.

Table 5.1 shows estimated imaging times for different pacing values. Use this table as a guide for matching the pacing value to the time your system needs to rasterize an image and send it to the PCR II Plus.

Run an image with the film recorder set to high speed as a test to begin to judge pacing values. Ultimately, you must rely on your own experience and testing to select a pacing value.

Pacing#	Typical Imaging Times (m:s)	
	35mm	
	2K	4K
HS (default)	0:29	0:58
7	0:34	1:07
10	0:47	1:34
15	1:10	2:19
20	1:32	3:04
25	1:55	3:49
30	2:17	4:34
35	2:40	5:20
40	3:02	6:05
45	3:25	6:50
50	3:47	7:35
75	5:40	11:20
100	7:33	15:06
125	9:26	18:51
150	11:18	22:37
175	13:19	26:22
200	15:03	30:08
225	18:49	37:39

*Table 5.1. Pacing values and corresponding imaging times.*

## Setting the Pacing Value

- Step 1: Press MENU once then press PREVIOUS or NEXT repeatedly until the message window displays SET PACING SELECT FUNCTION.
- Step 2: Press SELECT to enter the pacing submenu. The display shows PACING HS SELECT VALUE or PACING nnn where nnn is a number between three and 255. PACING HS has a pacing value of zero.
- Step 3: Press NEXT to increase the pacing number to a maximum of 255, PREVIOUS to lower the pacing number.
- Step 4: Press SELECT to choose a pacing value and exit the pacing submenu.
- Step 5: Press MENU once to return to the Ready menu.

## Guidelines for Selecting Pacing Values

- The pacing values you select vary with the speed of the equipment you use. With some rasterizers, you may need to use large pacing values.
- When imaging very complex graphics with photo drop-ins or large amounts of text, you may obtain better results by using a pacing value of seven to fifteen. This will have a minimal impact on the total imaging time.
- When using Mac Conductor, set the Pacing value in the FILM RECORDER PREFERENCES dialog. Mac Conductor ignores the pacing value set at the film recorder.

# Resolution Control

PCR II Plus can produce images at both 2K and 4K resolutions. This setting defines the number of individual data points or pixels the film recorder addresses and how quickly it completes an exposure.

**Note:** If you are imaging the PCR II Plus built-in test images, select the resolution using the SET RESOLUTION function. Normally, select the resolution mode from within the rasterizer (i.e., MVP Conductor or Mac Conductor).

To select 2K or 4K addressability:

- Step 1: Press MENU once, then NEXT or PREVIOUS until the display reads SET RESOLUTION SELECT FUNCTION.
- Step 2: Press SELECT to activate this choice, then press NEXT or PREVIOUS to toggle between the 2K and 4K settings (4K is PCR II Plus default setting).
- Step 3: Press SELECT to choose the addressability setting and exit from the SET RESOLUTION submenu.
- Step 4: Press MENU to return to the ready condition.

Chapter 6:  
**Color Balance**

# Introduction

The PCR II Plus provides controls that enable you to change the color balance of your output. This means that you can fine tune the film recorder for optimum results with the specific combination of film, processing chemistry, and, where applicable, printing paper, that you are using.

This chapter describes these controls and provides information about how to use them. It covers the following topics:

- Overview of the process of adjusting the color balance.
- How to expose test images.
- Brightness values and how to adjust them.
- Contrast values and how to adjust them.
- Repeat values and how to adjust them.
- General guidelines for adjusting the color balance.
- Special guidelines for using color print film with the PCR II Plus.

# Overview of the Process

This section gives an overview of the process of adjusting the color balance for a specific type of film.

- Step 1: Image the internal gray scale test (Test Image 1). This test image consists of sixteen boxes, each given a different exposure.
- Step 2: Use the densitometer to read each square of the test image. Measure densities for red, green and blue.
- Step 3: Record the results. Use the log sheets in the Appendix of this user guide to record the settings. Use graph paper or a spreadsheet program to plot the curves created by the density readings of the different boxes in the test image.
- Step 4: Compare measured density readings with the goal densities. See the section *Goal Density Tables* in this chapter.
- Step 5: Adjust the brightness values first. The objective is to get the measured density values in boxes 12 through 16 as close as possible to the goal density values.
- Step 6: Repeat the test image, process it, measure the density of the developed image. Compare the results with the goal densities.
- Step 7: Repeat steps 5 and 6 if necessary.
- Step 8: Adjust the contrast values after you adjust the brightness values. The objective is to get the measured density values in boxes 1 through 11 as close as possible to the goal density values.
- Step 9: Repeat the test image, process it and measure the density of the developed image. Compare the results with the goal densities.
- Step 10: Evaluate your results. Repeat steps 8 and 9 if necessary.
- Step 11: If the image is not bright enough or lacks sharpness, set a repeat value.

# Response Curves

The response curve is plotted from the density readings taken from the grayscale test image. See Figure 6.1, below.

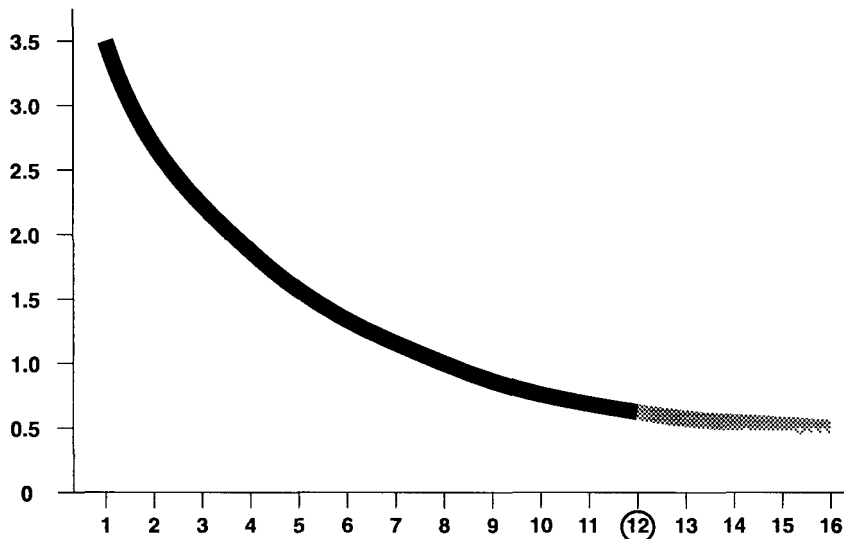

*Figure 6 1 A response curve for slide film*

*The vertical axis represents the measured density The horizontal axis represents the box number in which the density was measured*

Changes to contrast settings have the greatest effect on the densities measured in boxes 1 through 11, indicated by the black section of the curve above.

Changes to brightness settings have the greatest effect on the densities measured in boxes 12 through 16, the gray section in Figure 6.1.

# Channels

Each curve consists of three channels: red, green, and blue. When you change one channel, the whole curve moves in response.

For example, if you change only the red brightness value, then expose another test image, you see changes to the measured densities for all three colors.

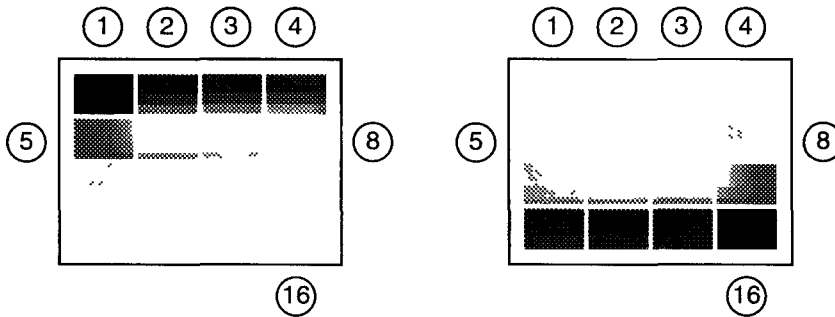

Figure 6.3 Test image 1, Gray Scale

Left, as it appears on slide film or on a print from a negative.

Right, as it appears on a negative

The numbering sequence begins at the top left and ends at the bottom right

# Exposing Test Images

Test images are part of the PCR II Plus software.

Use Test Image 1 to evaluate the color balance. See Figure 6.2 on page 6-4.

The Test Images 2 and 3 are used to evaluate other functions of the film recorder.

Specify the resolution and film type at the PCR II Plus front panel controls before you enter the test images submenu. This ensures that the PCR II Plus uses its default values when exposing test images. The default values yield optimum color balance for the test images. If you use customized values to expose the test images, your results may show poor color balance.

To expose a test image:

- Step 1: Turn on the PCR II Plus. With the front panel controls, select the resolution (2K or 4K), and the film type.
- Step 2: Press MENU then repeatedly press NEXT or PREVIOUS until the display reads TEST IMAGE SELECT FUNCTION.
- Step 3: Press SELECT to enter the test pattern submenu. The display shows TEST IMAGE # 1. You can select and expose the first test pattern or skip to others.
- Step 4: Press NEXT to scroll through the test pattern choices (TEST IMAGE#1 through TEST IMAGE#3).
- Step 5: Press SELECT to expose the selected test image. When the film recorder has finished, the display shows DONE, and the audio alarm emits four short "beeps."
- Step 6: Press MENU twice to return to the Ready state.

# Brightness Control

The Brightness Control enables you to shift the entire response curve up and down (see Figure 6-3).

Use the Brightness controls to enter different brightness values, repeat the test image, and measure until the lower portion of the curve is satisfactory. Decreasing the values increases the brightness of the image.

Shift the curve to find an acceptable light grey balance point (Box 12) and white point. The entire curve is affected when you change the brightness value, but the greatest effects occur in boxes 12 through 16.

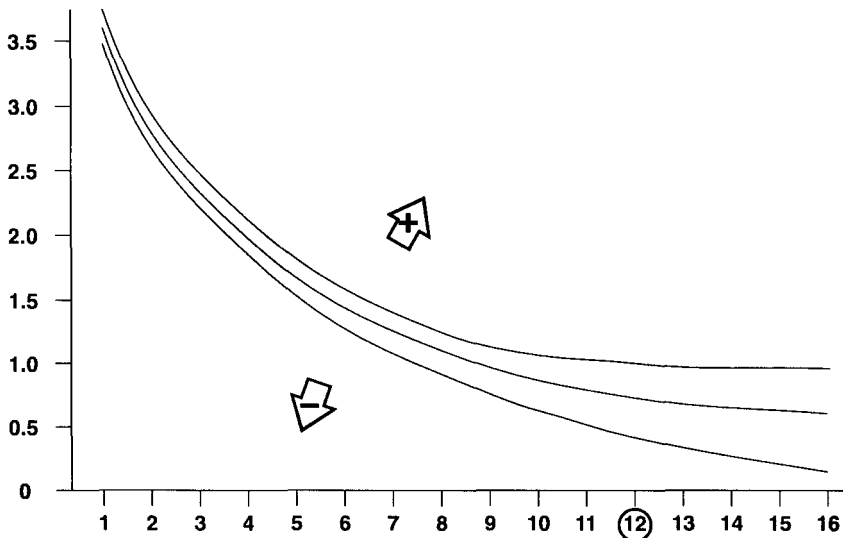

Figure 6-3 Changes to the brightness values have the greatest effect on the densities measured in boxes 12 to 16.

## Brightness Units

To lower the measured density and move the curve down, decrease the brightness number for a channel. To raise density, raise the brightness number (see Figure 6.3).

The numbers used to measure brightness values are arbitrary units that represent beam intensities for each of the three channels. For example, the red brightness value represents the red beam intensity. Possible brightness values might be the following:

Red: 69      Green: 82      Blue: 64

Because the values are arbitrary units, they are relative measurements. They do not represent the measured brightness of the beam or the measured density of the film.

For example, if the current brightness value is 55 and you change it to 45, the response curve will shift downward. Exactly how much the curve shifts depends on the film, processing, and other values. Because the effects of changes cannot be predicted exactly, color balancing requires running many tests in a process of trial and error.

**Note:** Brightness and contrast calibration errors may occur if the values selected exceed the CRT internal calibration range. Generally, this occurs when brightness values are decreased by more than 20 units for any channel. Try increasing the repeats value as described later in this chapter. To recover from a calibration error, see Chapter 7.

## Setting Brightness

To adjust the brightness:

- Step 1: Press MENU once, then press NEXT or PREVIOUS until the display reads SET BRIGHTNESS SELECT FUNCTION.
- Step 2: Press SELECT to display the current brightness setting for red. Selectable values range from 20 (produces a brighter shade) to 255 (produces a darker shade). Press NEXT or PREVIOUS to scroll through your available choices. Press SELECT again to choose a value.
- Step 3: Press NEXT to view and adjust the green and blue settings as above.
- Step 4: After you change the values, force a calibration. The new values do not take effect until the film recorder recalibrates.
- Step 5: After selecting values for all three colors, press MENU to return to the Ready state.

# Contrast Control

The Contrast Control affects the slope of the curve. Adjusting the contrast control number causes the curve to pivot up or down at the white point of the curve (usually box 16).

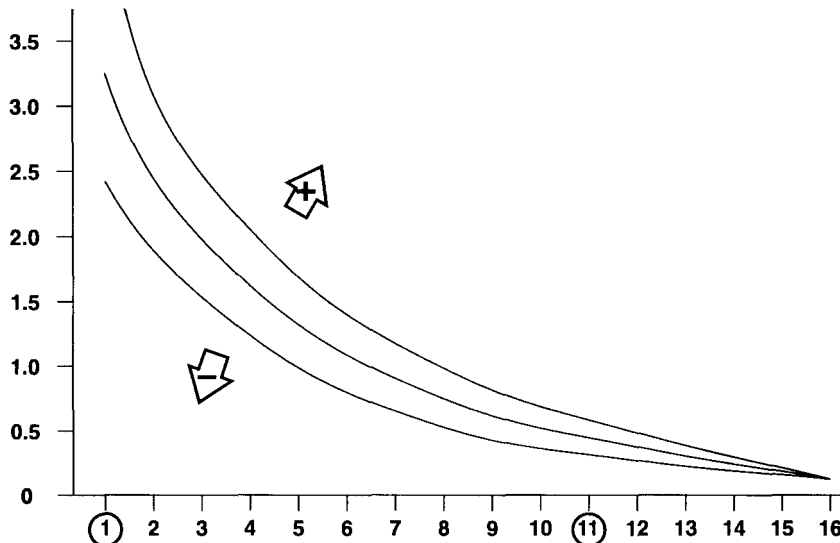

Figure 6.4. Changes to the contrast values have the greatest effect on the densities measured in boxes one to eleven.

## Contrast Units

Like the brightness values, the contrast values are arbitrary units representing beam intensities for the three channels. Changes affect the entire curve, but, unlike the brightness values, changes in contrast values are most apparent in boxes 1 through 11 (see Figure 6-4).

Examples of contrast values are the following:

Red: 69      Green: 91      Blue: 43

## Setting Contrast Values

To adjust the contrast, perform the following steps:

- Step 1: Press MENU once, then NEXT or PREVIOUS until the display reads SET CONTRAST SELECT FUNCTION.
- Step 2: Press SELECT to display the current contrast setting for red. Selectable values range from 20 (minimum contrast) to 255 (maximum contrast). Press NEXT or PREVIOUS to scroll through your available choices. Press SELECT again to choose a value.
- Step 3: Press NEXT to view and adjust the green and blue settings as above.
- Step 4: After you change the values, force a calibration. The new values do not take effect until the film recorder recalibrates.
- Step 5: After selecting values for all three colors, press MENU to return to the Ready state.

**Note:** To maintain a balanced grey around box 12, you may need to re-adjust the brightness value after changing the contrast value.

# Repeats

Repeats increase the number of times that each line of image data is imaged on the internal CRT (cathode ray tube). This increases exposure time.

## When to Use Repeats

As you adjust the PCR II Plus to obtain a brighter image, only so much can be achieved by lowering the brightness value. At a brightness value of less than 50, the PCR II Plus cannot produce any more light in the time it takes to image one line of image data (about 3 milliseconds). At this point, if you need a brighter image, increase the repeat value. As on a camera, this increases both the amount of time the line is scanned and the amount of light exposed onto the film.

## Increased Exposure

As the image data comes from the host computer and rasterizer, the data is scanned by the CRT one line at a time. For most 35mm films, one pass is sufficient to achieve the correct exposure on film. If one pass is not sufficient (especially on large format films), you can increase the repeat value and the image will spend more time on the CRT.

To increase the exposure or brightness of the image by 1 // stop or .30 density units, double the current repeat value and add 1. For example, if the current repeat value is 0, increase it to 1; if it is 1, increase it to 3; if it is 3, increase it to 7. Each time you double the repeat value, you get an image that is brighter by approximately one // stop, .30 density units, or 30CC.

## Repeats and Brightness

As the CRT brightness level becomes lower, the time it takes to expose the film increases proportionally. Reduced CRT brightness also reduces the CRT spot size. This gives better image quality. Increase the number of repeats to compensate for lower brightness.

## Setting the Repeat Value

To set the number of repeats:

- Step 1: Turn on the PCR II Plus and specify the resolution (2K or 4K) and the film type.
- Step 2: Press MENU and then NEXT or PREVIOUS until the message window displays SET REPEAT VALUE SELECT FUNCTION.
- Step 3: Press SELECT to enter the repeat values submenu. The display reads RED 0.
- Step 4: Press NEXT or PREVIOUS to scroll through the settings. You can specify a value from 0 to 10.
- Step 5: Press SELECT when the message window displays the repeat value that you want to use.
- Step 6: Press NEXT to display the current repeat value for green.
- Step 7: Repeat steps 4 and 5 to change the repeat value for green.
- Step 8: Press NEXT to display the current repeat value for blue.
- Step 9: Repeat steps 4 and 5 to change the repeat value for blue.
- Step 10: Press MENU to return to the ready condition.

# Tips and Tricks

Follow the guidelines in this section to get the best and most consistent results.

## **Allow thirty minutes for warm-up.**

To ensure that the PCR II Plus yields consistent results, let the film recorder warm up for at least thirty minutes before imaging film.

## **Give the process your undivided attention.**

Set aside uninterrupted blocks of time for using the film recorder. Do not expect to perform many tasks at once and still maintain close control of the variables used by the PCR II Plus. The faster you shoot film, process it, read it, plot it, make changes, and repeat the sequence, the more you minimize the effect of uncontrollable variables such as processor chemistry variations.

## **Change only one control at a time.**

This makes it easier to evaluate the results of your changes.

## **Use the same densitometer to take readings.**

Densitometers may vary in the readings they produce. To minimize variations caused by differences in densitometers, use the same equipment for all readings.

## **Record your actions and readings regularly and clearly.**

Keep a log of settings and results, including densitometer readings. The Appendix of this user guide contains blank log sheets that you may photocopy.

## **Plot your data and evaluate it.**

Use graph paper, log sheets (see the Appendix of this user guide), or spreadsheet software.

## **Minimize variables.**

Variables—such as film type, film lot, processing chemistry—must be controlled as much as possible to ensure consistent, high-quality results.

**Do not decrease brightness by more than 20 points.**

Brightness and contrast calibration errors may occur if you select values that exceed the CRT's internal calibration range. This occurs mostly when the brightness is increased (i.e., brightness values are decreased) by more than 20 points for any color. If the desired brightness level is not achieved before a calibration error occurs, repeats must be added. Refer to Chapter 7 for how to recover from a calibration error (93).

**Get the numbers as close as you can.**

As you color balance your film recorder, your film may not match your goal densities exactly. You have succeeded if your grayscale is well-balanced but your curve is 10 under goal across the entire curve.

**Beware of channel cross-over.**

Channel cross-over occurs when a change to the brightness or contrast in one channel causes changes to another channel. Expect cross-over when you make large adjustments during initial trial bracketing. As you increase your experience with the PCR II Plus, you will learn to gauge how much cross-over to expect from your changes.

**Sacrifice white/black for good-looking midtones.**

You may not be able to pull out every bit of cross-over and maintain a perfect white or dark shadow. Errors or cross-over in the curves is most obvious in the mid-tones, although, past a certain point, white looks white and black looks black to all but a few eyes. You may want to sacrifice a perfect white or black for the sake of improved midtones.

**Reading and Plotting Densities**

Instead of taking measurements of all sixteen boxes for every test image, you may want to measure just 5 of the boxes. Normally, boxes 2, 4, 8, 12, and 16 give you enough data to analyze and plot a curve. Remember, Dmin—box 1—is a product of variables over which the PCR II Plus has no control.

## Film Guidelines

### **Use the same film type.**

Changing back and forth among different types of film can cause confusion, discarded film runs, and wasted time and money.

### **Use film from the same batch or lot.**

Use film with the same emulsion number whenever possible. The most consistent results are obtained from the same film batch. Check the film batch data printed on the side of the film box.

### **Store film under recommended conditions.**

Follow the film manufacturer's recommendations for storing your film. These recommendations include the temperature and humidity conditions best suited to the film.

### **Use the same lab to process all your film.**

This minimizes the variables in processing equipment and supplies.

### **Always Verify the Film Type**

Before you modify the brightness or contrast values, make sure that the film type you specified at the PCR II Plus control panel matches the type of film that is loaded in the camera module. If not, use the SET FILM TYPE function to select the correct film type.

## Changes and Default Settings

Changes to the brightness, contrast or repeat values are saved as the new default settings for the currently specified film type. FILM SELECT commands from Agfa and third-party rasterizers will load these customized settings.

Use the RESET DEFAULTS function to restore the original settings provided in the film recorder firmware.

## Dmax and Dmin

Dmax (density maximum) is the densest point on a scale of black to white. With the PCR II Plus, Dmax is the measurement taken from Box 1 on Test Image #1.

Dmin (density minimum), the opposite of Dmax, is the measurement taken from Box 16 on Test Image #1.

Dmax and Dmin are determined not only by the PCR II Plus, but also by the film, processing, paper, and printing. Chrome film, for example, always has density even if you exposed it to the sun for an hour before processing it. Every photographic printing paper has a published Dmax and Dmin for the print side.

An image with a Dmin within 0.02 to 0.04 density units of the medium's Dmin is probably successful.

To evaluate your Dmax, read some exposed media and compare that to your test image. Consider the image successful if the Dmax is within a few density units of the exposed media. Tiny imperfections in the Dmax are caused by ambient exposure within the PCR II Plus, usually a result of stray light reflecting from other parts of the test image.

## Increments and Channels

While adjusting the color balance of your PCR II Plus, image a series of test frames with different brightness, contrast, or repeat settings. Your initial tests should tell you in which direction the curves need to move, but not the exact combination of settings required to produce the goal.

If large changes are required, make those changes in increments of 5 units to one channel of either the brightness or contrast values. Change only one channel a time. If you change all three channels at once, you will not know which values are responsible for each result. As you near your goal, use an increment of 2 units.

## **Trial and Error**

Finding the best combination of brightness, contrast, and repeat values is largely a result of trial and error. Expect to try many combinations with multiple film runs and grayscale rejects. Record your settings and readings carefully. Take the time to watch and learn how the film reacts as you image and analyze.

## **Gauging the Effects of Changes**

When making changes to the Brightness value, use boxes 12 through 16 as controls. Remember that you may need to tolerate imperfection in box 16 in order to pull out the last bit of cross-over in the curves.

To measure the effects of changes to the contrast values, use box 2 as your gauge. You may need to tolerate imperfection in box 2 to achieve your best midtones. Therefore, when you are close to your final numbers, analyze the entire curve, not just box 2 to gauge the effects of contrast adjustments.

## **Off-Color Slides**

Make sure that the film you are using is supported for the module you are using. If you are using a supported film, you may need to adjust the color balance settings to obtain better results. Variations in film or processing can result in off-color slides even if you are using a supported film.

The PCR II Plus recommended warm-up time is at least 30 minutes. Observe the warm-up period recommendations discussed in Chapter 3 of this manual.

# Guidelines for Print Film

Follow these steps to color balance for print film:

- Step 1: Use the PCR II Plus control panel to expose Test Image 1 and develop the film.
- Step 2: Use a standard setup negative to determine exposure and filtration settings for your color printer. Make sure that the standard negative is of the same type of film that you are using in your film recorder.
- Step 3: Use the exposure and filtration settings from step 2 to print the negative of Test Image 1.
- Step 4: Adjust film recorder brightness and contrast (see the section *Overview of the Process* in this chapter) so that when you print the test image, box 8 has these reflection densities:  
Red: 0.87    Green: 0.83    Blue: 0.85

Here are additional guidelines:

- If you are working without a densitometer, adjust film recorder brightness and contrast settings so that, when printed, box 8 or box 9 look like middle gray with no red, green, or blue tint.
- When using a minilab-type printer that automatically scans a negative to determine exposure and filtration settings, turn this feature off when printing negatives from the film recorder.
- To create your own standard setup negative: In normal daylight conditions, photograph a neutral gray card or subjects with a good range of flesh tones. Use a standard camera and the same film used in your film recorder. The goal is to produce a well-balanced, properly exposed negative to use for setting up your color printer.

# Goal Density Tables

This section contains three tables that list goal densities for different types of film. It also provides information about the goal densities you should achieve when rendering digital images on continuous-tone color film recorders using various types of media.

These tables specify goal densities for the neutral gray tone scale only. Results have shown that if good neutral balance and a pleasing tone scale are achieved, the rendering of non-neutral colors will also be pleasing.

In some tables, the darkest goal densities ( $D_{max}$ ) are not specified. This is because the hue of the media at its darkest point depends on the film and cannot be controlled in software.

If  $D_{max}$  values are specified, they can be used optionally if it is desirable to output the darkest neutral color available rather than a darker but non-neutral  $D_{max}$ .

## Slide Films

The term *slidefilms* refers to films in the same class as Agfachrome®, Ektachrome®, etc. The table for slide films has been calculated to apply to all films in this class.

Box	R	G	B
1	-	-	-
2	2.38	2.36	2.34
3	1.98	1.96	1.94
4	1.69	1.67	1.65
5	1.46	1.44	1.42
6	1.28	1.26	1.24
7	1.12	1.1	1.08
8	0.99	0.97	0.95
9	0.87	0.85	0.83
10	0.77	0.75	0.73
11	0.68	0.66	0.64
12	0.59	0.57	0.55
13	0.51	0.49	0.47
14	0.44	0.42	0.4
15	0.37	0.35	0.33
16	0.31	0.29	0.27

\* The type of slide film that you use and the way you process the film affect the goal density values in Box 1 . For slide films, the goal density in Box 1 should be equal to or greater than the density in an unexposed region minus 0.10 D.

## Print Films

There are two tables for color print film. The following films are supported:

- Agfa Optima® 125.
- Kodak® Vericolor® III Type-S (VPS) film.

These separate tables are provided to match the expectations of photo-finishers who use different printing conditions for each film type. Color negative films could share a common table of Goal Densities matched to a single set of printing conditions.

**Agfa Optima 125**

Box	R	G	B
1	0.34	0.59	0.77
2	0.53	0.88	1.16
3	0.59	0.96	1.24
4	0.65	1.03	1.30
5	0.70	1.09	1.36
6	0.75	1.15	1.42
7	0.79	1.21	1.47
8	0.84	1.26	1.52
	0.88	1.30	1.57
10	0.91	1.35	1.61
11	0.95	1.40	1.65
12	0.99	1.45	1.70
13	1.04	1.51	1.75
14	1.10	1.59	1.82
15	1.18	1.70	1.92
16	1.31	1.89	2.08

### Kodak Vericolor III Type S (VPS)

Box	R	G	B
1	0.28	0.78	.89
2	0.45	1.03	1.18
3	0.52	1.12	1.26
4	0.58	1.19	1.32
5	0.63	1.26	1.38
6	0.68	1.32	1.43
7	0.72	1.37	1.48
8	0.75	1.42	1.52
9	0.79	1.46	1.56
10	0.82	1.50	1.60
11	0.85	1.55	1.64
12	0.89	1.60	1.68
13	0.93	1.66	1.73
14	0.99	1.74	1.79
15	1.07	1.85	1.87
16	1.22	2.03	1.99

The goal densities in this table are intended for use when the final print is made on Kodak Ektacolor®-!! Paper.

Chapter 7:  
**Troubleshooting**

# Introduction

This chapter contains the following information:

- Lists of status and error messages, and descriptions of what they mean.
- Descriptions of general problems you may encounter while using the PCR II Plus and solutions to those problems.
- Procedures to recover from calibration errors.
- How to restore data stored in memory powered by a back-up battery after a battery failure.
- Descriptions of hardware problems and how to fix them.

# Status and Error Messages

This section shows the status and error messages and briefly explains what they mean.

## **WARMING UP ROM OK RAM OK**

PCR II Plus executing a power on warm-up cycle that tests its internal electronics and calibrates its brightness levels.

## **CALIBRATING**

The film recorder is calibrating its brightness levels.

## **READY AG100 PLS 4K 1**

This message indicates that the film recorder is ready to accept data and shows the selected film type and resolution settings. The 1 is the current frame count.

## **NO MODULE**

There is no camera module attached to the film recorder. If there is indeed a camera module, check the connection of the camera cable and inspect it for any bent or broken pins.

## **REMOTE**

Indicates that the film recorder has received a command from the host computer and that it is now under remote control.

## **RECORDING RED**

PCR II Plus is recording the red component of a color image onto the film.

## **RECORDING GREEN**

PCR II Plus is recording the green color pass onto film.

## **RECORDING BLUE**

PCR II Plus is recording the blue color pass onto film.

## **END OF FILM**

You have reached the end of film. Refer to the film loading and unloading instructions for loading fresh film and clearing the end of film message.

**COMMAND BYTE**

The PCR II Plus has received an unrecognized command. Check your system and the film recorder connectors. If the error persists, call for service.

**DATA BYTE**

PCR II Plus has received unrecognized data. Check your host system and the film recorder connectors. If the error persists, call for service.

**INTERNAL MEMORY**

Turn off the film recorder and wait 30 seconds. Turn the film recorder back on and retry the image. If the error persists, call for service.

**GPIB INTERFACE**

The PCR II Plus detected a communication problem while using the GPIB communication interface. Check your connections. If the error persists, call for service.

**SCSI INTERFACE**

The PCR II Plus detected a communication problem while using the SCSI communication interface. Check your connections. If the error persists, call for service.

**BRT CAL**

There is a problem with the CRT. Call for service.

**CNT CAL**

There is a problem with the CRT. Call for service.

**MODULE FAULT**

A function was requested that requires the use of the camera module, but no module was detected. Install the camera module on the film recorder's front panel. Make sure that the camera connector is securely plugged in. If problems persist, call for service.

**FILTER WHEEL**

There is a problem with the filter wheel. If the error persists, call for service.

# Possible Problems and Solutions

This section provides troubleshooting techniques to help you isolate and correct problems you may encounter during normal operation of the film recorder. If you encounter a problem that you cannot fix, call for service.

**WARNING:**

There are no user-serviceable parts inside the PCR II Plus. Never remove the side cover to access interior components.

## Power Indicator Does Not Illuminate

If the PCR II Plus does not turn on, then the power cord may not be plugged into an outlet that provides the proper line voltage. If the power cord connection appears to be good, then one of the film recorder's internal fuses may be blown. Contact an authorized service representative for the proper procedures to replace a blown fuse.

## PCR II Plus Resets Suddenly

A sudden hardware reset may occur if there are transient voltage spikes or a brown-out condition on the AC power line. The PCR II Plus should have its own dedicated power line with surge protection. Unplug any other equipment that uses the same power outlet as the PCR II Plus and be sure your setup complies with the electrical and environmental specifications given in the Appendix of this manual.

## **Computer Locks Up on Large image Files**

Some host computers may not have enough memory to process large image files. You may have to reconfigure your system to obtain proper operation. If this does not work, contact your Agfa dealer for additional support.

## **35mm Film Will Not Load**

Make sure that the power switch on the 35mm camera is set to the ON position. Also check that the camera connector is properly seated.

## **System Locks Up When You Touch Film Module**

The system may lock up if there is a static discharge between you and the film module when you touch it. Your body can accumulate a sizeable static charge if the working environment has very low relative humidity, or if PCR II Plus is located in a carpeted area.

The easiest way to lower the risk of a static discharge to the film module is to first touch PCR II Plus outer cabinet. The cabinet is electrically grounded and can dissipate most static discharges that your body generates.

If the problem persists, invest in a high-quality, anti-static floor mat for the immediate area in which the PCR II Plus is located. Anti-static mats are available from computer supply houses and usually have a grounding wire that connects to the wall outlet.

# Calibration Errors

The messages **BRT CAL** and **CNT CAL** indicate calibration errors. The PCR II Plus is unable to calibrate due to one of the following conditions:

- The brightness or contrast values have been modified to a level that exceeds the CRT's internal calibration range.
- A hardware failure has occurred.

Four different procedures are described in this section. In the event of a calibration error, try them in this order:

1. *Calibration Out of Range*
2. *Reset Film Type*
3. *Reset Defaults*

For example, if the procedure *Calibration Out of Range* does not clear the problem, go on to the next procedure on the list. If the error persists after you try all four procedures, call for service.

## Calibration Out of Range

If you suspect that there is a problem with the internal calibration of the PCR II Plus, initiate the calibration routine using the film recorder's front panel keys.

**Step 1:** Press **MENU** then press **NEXT** or **PREVIOUS** until the message window displays **CRT CALIBRATION SELECT FUNCTION**.

**Step 2:** Press **SELECT** to initiate the calibration routine, which resets the calibration points to their optimal levels.

## Reset Film Type

Follow this procedure:

- Step 1: Press RESET.
- Step 2: Press MENU.
- Step 3: Select SET FILM TYPE from the menu. Change to a film type other than the one currently specified. This resets the look-up table, brightness, contrast and repeat values to different settings, clearing the calibration error.
- Step 4: If the PCR II Plus calibrates, then change back to the original film type and recalibrate.

## Reset Defaults

**Caution:**

This procedure resets the PCR II Plus to its default settings and erases all custom settings. Make sure that you have records of all custom data and look up tables before you proceed.

Follow this procedure:

- Step 1: Press RESET.
- Step 2: Press MENU.
- Step 3: Select RESET DEFAULTS from the menu. This resets the look-up table, brightness, contrast and repeat values to their factory settings, clearing the calibration error.

# Battery Problems

When you turn on the film recorder, it checks look up table, color filter correction and DAC values. These values are stored in memory powered by a back-up battery. If an error is detected, one of the these messages appears in the message window:

- **?LUT CHECKSUM ERROR**  
The look-up table values for the current film module (and maybe others) have been corrupted. To reload them, follow the procedure *Reloading Look Up Table Values* in this section.
- **BATTERY! ERROR**  
The factory-set color filter correction and DAC values are no longer intact. To reset them, follow the procedures *Resetting Filter Correction Values* in this section.

## Reloading Look Up Table Values

Follow this procedure to reload look up table values:

- Step 1: Press the RESET button on the PCR II Plus front panel to clear the error message and render the unit operational.
- Step 2: Next, to reload and store default brightness and contrast settings, select the SET FILM TYPE function via the front panel display.
- Step 3: To customize brightness and contrast settings, follow the procedures described in Chapter 6. If the error message appears again after power-up, call for service.

## Resetting Filter Correction Values

In the event of a battery failure, enter the color correction filter values recorded on the label on the back panel. Follow this procedure:

- Step 1: Press RESET to clear the BATTERY! ERROR message.
- Step 2: Press MENU once, then press PREVIOUS or NEXT until the message SET BRIGHTNESS SELECT FUNCTION appears.

- Step 3: Press SELECT. The message window displays the current brightness value for red.
- Step 4: To display the brightness filter submenu, press and hold MENU and SELECT at the same time. After the PCR II Plus beeps once, release only MENU. Listen for a second beep, and release SELECT.
- Step 5: Enter the three brightness numbers like this:
- Press PREVIOUS or NEXT to change the red setting.
  - Press MENU to access the green setting.
  - Press PREVIOUS or NEXT to change the green setting.
  - Press MENU to access the blue setting.
  - Press PREVIOUS or NEXT to change the blue setting.
  - Press SELECT to return to the main menu.
- Step 6: To enter the contrast filter settings, press MENU to again arrive at the SET BRIGHTNESS display.
- Step 7: Press SELECT.
- Step 8: To display the contrast filter submenu, press and hold MENU and SELECT at the same time. This time, release only SELECT after the first beep, and release MENU after the second beep.
- Step 9: Enter the contrast filter numbers following the same procedure in Step 5.

## **Recurring BATTERY! ERROR Messages**

If the message BATTERY! ERROR appears again after power up, indicating a battery failure, contact an authorized service representative.

# Hardware Problems

This section discusses compatibility issues between PCR II Plus and other hardware devices.

## Macintosh SCSI Interface Troubleshooting

If you are using the PCR II Plus with a Macintosh host computer and you cannot access the film recorder, check the following, one at a time.

- Make sure that PCR II Plus is on.
- Make sure that PCR II Plus is in the idle state and the front panel message window indicates a ready condition.
- Check the PCR II Plus SCSI address. Make sure that it is unique.
- Make sure that the end of the SCSI chain is terminated.
- Try disabling the PCR II Plus internal termination.
- Try using a single SCSI cable between the Mac and PCR II Plus, or try using another set of SCSI cables.

## General Image and Rasterization Problems

Various image quality problems may occur when you use third-party rasterizers not designed specifically for film-recording applications. Some problems may be caused by the rasterizer's inability to keep up with PCR II Plus imaging speed. Use the PCR II Plus pacing control to ensure a smooth data flow from a slower rasterizer. See Chapter 5 for more information about pacing control.

# Appendix

# Technical Specifications

## Input

Run length encoded or straight pixel representation of red, green and blue data.

Bits/pixel: 24 (eight each for red, green and blue).

## Data Interface

IEEE Standard 488-1978 (GPIB) and SCSI, user selectable.

## File Formats

PC Environment:

- SCODL (through MVP)
- Adobe PostScript (through ChromaScript or third-party rasterizers)
- Direct Drivers

Macintosh Environment:

- PICT, PICT II, 32-bit PICT, and 24-bit TIFF (through Mac Conductor)
- Adobe PostScript (through ChromaScript or third-party rasterizers)
- Direct Drivers

## Film Formats

- 35mm rolls, 36 frame maximum
- 35mm bulk load (100 ft. film rolls)
- 120/220 (medium format) roll film, 10 or 20 frames
- 4x5 sheet film

## Supported Films

The following films are supported.

- Agfachrome RS100 Professional
- Agfa Optima 125 negative 35mm, 120/220 and 4x5
- Kodak Ektachrome ISO 100 Professional EPN
- Kodak Vericolor III Type S

For all types listed above, 35mm, 120/220 and 4x5 formats are supported.

## Addressability

35mm: 4096 x 2732 pixels and 2048 x 1366 pixels (at 2:3 aspect ratio for 35 mm).

120 and 4 x 5 film: 4096 x 3072 pixels and 2048 x 1536 pixels (maximum at 3:4 aspect ratio).

## Power Requirements

Universal AC input, automatically selectable.

100VAC to 240VAC  $\pm 10\%$ , 47-63Hz @ 1.0A

## **Physical**

Depth: 17.7" (450mm)

Width: 11.5" (292mm)

Height: 35.8" (910mm)

Weight: 46 lbs.

## **Environmental**

Storage: 32° to 158°F (0° to 70°C)

Operating: 59° to 86°F (15° to 30°C)

Relative Humidity: 35% to 65% non-condensing

## **EM/RFI**

The PCR II Plus is designed to meet FCC specifications according to CFR 47, Docket 20780, part 15, subchapter J for class A operation with respect to EMI/RFI emissions. As of the effective date of this publication, final approval is pending.

## **Safety Standards**

The PCR II Plus is designed so that it complies with all major safety standards, including CSA 950, IEC 950 and UL 1950. As of the effective date of this publication, final approval is pending.

# Theory of Operation

The PCR II Plus microprocessor decodes input data it receives from the host through an interface cable and controls the CRT beam path and intensity. The CRT can produce up to 256 shades of gray for each of three primary color recordings — red, green, and blue. This color additive process can produce a theoretical total of 16.8 million colors, although the actual number of colors seen is limited by the capabilities of the film and human eye, as well as other factors.

The microprocessor rotates the filter wheel, controls the camera shutter and advances the film.

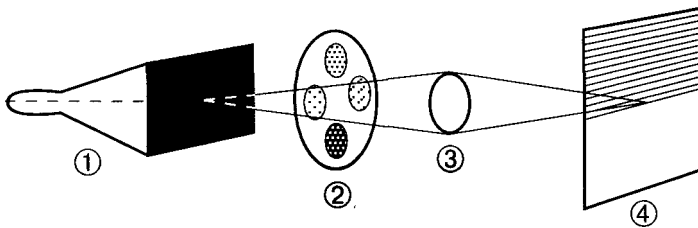

Figure A-1. PCR II Plus Imaging Process.

①—CRT. ②—Color wheel with red, green, blue filters, ③—Lens. ④—Film.

The CRT images the computer-generated data in the form of a traveling spot of light. The filter wheel electronically selects the color filter that the light will pass through, and a lens focuses the light on the film. The shutter in the film back opens to allow film exposure.

Images are created by exposing the film to each location along the scan line for the amount of time per color as specified by the incoming data.

After completing a color pass, the filter wheel rotates, and the process repeats until all three primary colors have been recorded.

PCR II Plus uses an intensity modulated film recording process; that is, the light intensity of the CRT's electron beam varies for each pixel exposure while the amount of time spent on recording each pixel stays the same.

# User Log Tables

This section contains two different blank tables. Make copies of them for use as you work with your PCR II Plus.

Use Table 1 to record your PCR II Plus user programmable settings. For example, you can use it:

- For keeping records of the changes you make as you develop and refine your color balance settings.
- To record your final color balance settings as insurance against a catastrophic data loss.
- To record the settings that different operators or different customers prefer.

You may find this table especially useful if several people work with the film recorder and use different film types, pacing values or color correcting settings.

Use Table 2 as you color balance your system. There are spaces to record and plot measured densities and the settings used to get those densities.

USER LOG TABLE 1	
USER NAME:	DATE:
MODULE TYPE:	Serial No.:
FILM TYPE	<input type="checkbox"/> AGFACHROME RS 100 PROFESSIONAL <input type="checkbox"/> AGFA OPTIMA 125 NEGATIVE FILM <input type="checkbox"/> KODAK EKTACHROME ASA100 PROF EPN <input type="checkbox"/> KODAK VERICOLOR TYPE III S
PACING VALUE	HS. or 3 to 255:
GPIB ADDRESS	0 to 30 (even number):
SCSI ADDRESS	0to6:
BRIGHTNESS	RED (20-255): GREEN (20-255): BLUE (20-255):
CONTRAST	RED (20-255): GREEN (20-255): BLUE (20-255):
RESOLUTION	<input type="checkbox"/> 2K <input type="checkbox"/> 4K
REPEAT VALUE	RED 0 to 10 GREEN 0 to 10 BLUE 0 to 10
CALIBRATION	<input type="checkbox"/> ENABLED <input type="checkbox"/> DISABLED

# Glossary

This glossary defines terms for the purposes of using and programming the PCR II Plus. These meanings may not coincide with other uses nor with formal definitions.

## **Brightness Level**

One of nine CRT intensities (0 through 8). The user or the internal system assigns a subset of intensities to red, green and blue colors in a given mode.

## **Bus**

A circuit path over which information passes.

## **Cathode Ray Tube (CRT)**

A vacuum tube in which an electron beam, directed at a phosphor-coated glass screen, causes a point on the screen to glow. As magnetic coils deflect the beam, the point of light moves across the screen. Variations in the intensity of the beam create a contrasted visible display on the screen.

## **Checksum**

The result of summing data bytes after a data transfer. The resultant checksum is used to verify that the data were transferred properly.

## **DIP Switch**

A set of switches encased within a single package (a "dual in-line package" or DIP) which can be set by hand.

## **DRAM**

A form of memory, continually refreshed, possessing both read and write capability. Memory contents are lost when the power is turned off.

**Filter Wheel**

A movable wheel containing three color filters and one dark filter which reside in the optical path and color the imaging beam.

**GPIB**

General Purpose Information Bus; also known as IEEE 488-1978 interface. A standard data communications interface that allows high-speed transmission of data from one device to another.

**Hexadecimal**

The representation of numbers in the base-16 number system, using the ten digits 0-9 and the six letters A through F.

**Host Computer**

A computer from which the film recorder receives image data and commands via the SCSI or GPIB Bus.

**Initiator**

A SCSI device (usually a host system) that requests an operation to be performed by another SCSI device.

**Intensity Calibration**

Checking the CRT hardware to ensure it matches the intensity value for each of the levels in the brightness table. The film recorder automatically adjusts this intensity value. Calibration may be performed either automatically or manually.

**Least Significant Bit**

In a binary number, the bit representing the lowest exponent of 2.

**Look-up Table (LUT)**

A table translating one set of values into another based on a known relationship. LUTs compensate for nonlinear film sensitivity. Different LUTs are required to produce similar results on different film types.

**Microprocessor**

The component of the film recorder (and of microcomputers) which performs logic, computational and control functions.

## **Optical Path**

The path that the light emitted by the CRT follows through the filter wheel and lens to the film.

## **Peripheral Device**

A peripheral that can be attached to a SCSI device (e.g., magnetic disk, printer, optical-disk, or magnetic tape).

## **Pixel**

Abbreviation for picture element. The smallest defined element into which an image resolves. The term refers to both the smallest defined segment of a scan line (a unit of width) and to a two dimensional screen area one pixel wide and one line high.

## **Power-up Sequence**

The series of operations the PCR II goes through when the user turns the power on. During this time, the film recorder:

- Tests its internal systems
- Sets all SCSI functions to the idle state
- Performs memory diagnostics
- Loads default LUT values, brightness tables and brightness levels
- Resets the film recorder

## **Reset Sequence**

A sequence of operations the film recorder goes through when the user presses the Reset switch.

## **SCSI**

Small Computer System Interface. A standard data communications interface that allows high-speed transmission of data from one device to another.

## **SCSI Device**

A host computer adapter or a peripheral controller or an intelligent peripheral that can be attached to the SCSI bus.

**Target**

A SCSI device that performs an operation requested by a host or initiator.

**XCS-36**

Extended Color Support, 24-bit data input. A color control technology developed by Agfa that compensates for the nonlinear response of film and CRTs, and provides the broadest range of perceptible colors.

# Primary and Secondary Error Codes

When PCR II Plus detects an error, it displays an error message on the control panel message window. It also sends a *primary code* to the host computer. This is a numerical value that represents the error. *Secondary codes* are additional numerical values that further define the error.

This section lists the primary codes and describes the associated secondary codes.

Programmers and service technicians can obtain the primary and associated secondary error codes by sending a Read Extended Fault Status command from the host (GPIB version) or sending a Request Sense command from the host (SCSI version).

Table 7.2 lists the primary error code numbers, the corresponding message that appears on the control panel LCD, and a brief description of the error.

Primary Code	Message	Description
83	COMMAND BYTE	Illegal Command Byte
84	DATA BYTE	Illegal Data Byte
91	INTERNAL MEMORY	Memory Fault
92	GPIB INTERFACE SCSI INTERFACE	GPIB Interface Fault SCSI Interface Fault
93	BRT CAL CNT CAL	Brightness Calibration Fault Contrast Calibration Fault
A1	MODULE FAULT	Camera Module Fault
A2	FILTER WHEEL	Filter Wheel Fault

Table 7.2. Primary error codes.

## **Code 83: Illegal Command Byte**

**Secondary Code: 00, 01**

While the film recorder was in the idle state, it received an unrecognized command. The illegal command byte is contained in register H.

**Secondary Code: 02**

The film recorder received a command with an illegal parameter. The command byte is contained in register H, and the illegal parameter is contained in register L.

## **Code 84: Illegal Data Byte**

**Secondary Code: 01**

The film recorder received an illegal run-length code (a length of zero). This code is contained in register E and indicates a special function. The function code (INTENSITY) does not correspond to any of the allowed codes. Function codes are contained in register C.

**Secondary Codes: 02, 03, 04**

02 indicates that the initial horizontal address was less than the allowed minimum.

03 indicates that the calculated end address was greater than the allowed maximum.

04 indicates that the calculated end address was less than the start address.

For all three errors:

- H and L contain the horizontal start address
- D and E contain the end address
- B and C contain the pixel count

### **Secondary Codes: 05, 06, 07**

The film recorder used the image parameter information it received and calculated an illegal vertical video address.

- 05 indicates that the initial vertical address is greater than the allowed maximum.
- 06 indicates that the calculated end address is less than the allowed minimum.
- 07 indicates that the calculated end address is greater than the start address.

For all three errors:

- Register pair H and L contain the vertical start address
- D and E contain the end address
- B and C contain the number of lines per scan

### **Secondary Code: 08**

A nonexistent internal look-up table was requested.

### **Secondary Code: 09**

The film recorder received an illegal intensity assignment.

### **Secondary Code: 0A**

The calculated horizontal endpoint was no longer within the digital image map after the image rotated by 90 degrees.

- Register HL contains the horizontal start address.
- DE contains the horizontal end address.
- BC contains the horizontal line length.

### **Secondary Code: OB**

The calculated vertical endpoint was no longer within the digital image map after the image rotated 90 degrees.

- HL contains the vertical start address
- DE contains the vertical end address
- BC contains the number of lines per scan

### **Secondary Code: OC**

While imaging in mixed RLC/pixel mode, the pixel count exceeded the line boundary.

## **Code 91 : Memory Error**

### **Secondary Code: 00, 01**

Reason for Error: Prior to imaging, the film recorder verifies the checksums of various RAM data areas, such as the color look-up tables (LUTs). This code indicates corruption of a RAM data area.

### **Secondary Code: 02 to 07**

On a power-up or reset sequence, the film recorder detected a memory failure during its memory diagnostics test.

Code 02 indicates an EPROM checksum failure; the remaining codes indicate RAM failures. Bring errors of this nature to the attention of a qualified service technician.

## **Code 92 (PC): GPIB Interface Error**

### **Secondary Code: 00**

When an operator attempted to start a local test pattern, the film recorder was unable to put the GPIB interface into the local mode of operation. The film recorder did not initiate a test pattern.

### **Secondary Code: 01**

The GPIB experienced a handshake error while transmitting or receiving data. Check your connections.

## **Code 92 (Macintosh): SCSI Interface Error**

### **Secondary Code: 00**

The film recorder has detected a parity error during data transfer from the host.

### **Secondary Code: 01**

SCSI Controller fault.

## **Code 93: CRT Brightness or Contrast Calibration Error**

### **Secondary Code: 00, 01**

Code 00 indicates that the CRT beam is too bright.

Code 01 indicates that the CRT beam is too dim. If the film recorder is unable to maintain proper CRT intensity, contact your Agfa service representative.

## **Code A 1 : Module Error**

**Secondary Code: 01**

An invalid module identification code was detected.

## **Code A2: Filter Wheel Error**

**Secondary Code: 00 to 05**

The camera module is experiencing problems in reliably moving the filter wheel.

Contact an authorized service representative.

# Index

35mm bulk loading module, 1-4  
35mm module, 1-4  
4x5 module, 1-4

## A

Address, 2-12  
Addressability, 3-8, 5-6, A-2  
Advancing film, 4-4  
Agfachrome, 4-7  
Anti-static floor mat, 7-5

## B

Back panel, 1-10  
Battery, 7-8  
Battery failure, 1-10, 7-9  
Beam intensity, 6-7  
Beeper, 3-11  
Brightness, 6-12  
    settings, 6-3  
    values, 3-7, 6-2, 6-6, 6-7  
Brown-out, 3-3, 7-4  
Buttons  
    MENU, 1-7  
    NEXT, 1-7  
    PREVIOUS, 1-7  
    RESET, 1-7  
    SELECT, 1-7

## C

Calibration, 3-8, 5-2, 6-10  
    errors, 4-7, 6-7, 6-14, 7-6  
    sequence, 3-2  
Camera backs, 2-15  
Channels, 6-4, 6-7, 6-9  
Color correction filter values,  
    1-10, 7-8  
Color print film, 6-21  
Communication protocol, 2-11  
Contrast settings, 6-3  
Contrast values, 3-7, 6-2, 6-9  
Cross-over, 6-14  
CRT, A-4  
CRT brightness levels, 4-6, 4-7

## D

DAC values, 1-10  
Daisy chain, 2-4  
Dedicated power line, 7-4  
Default settings, 3-7, 3-11  
Densitometer, 1-3, 6-2  
Depth, A-3  
Device address, 2-12-2-13, 3-7  
Diagnostic test, 3-2  
Digital images, 6-19

Display language, 2-14

Dmax, 6-16, 6-19

Dmin, 6-16

## E

Ektachrome, 4-7

End-of-film condition, 4-2

Errors, 3-11

Error messages, 7-2

    Primary error codes, A-13

## F

FCC compliance, A-3

Film processing, 6-15

Film type, 4-6-4-7, 6-15

Filter correction values, 1-10

Filter wheel, A-4, A-10

Frame counter, 3-6, 4-5

Front panel, 1-6, 3-4

Fuses, 1-9, 7-4

## G

Goal densities, 6-2, 6-19

GPIB, 2-4, A-10

    address, 2-12

    communication, 2-5

    device address, 3-7

    interface port, 1-9

GPIB/SCSI switch, 1-7, 2-11,  
3-9

Grounding, 2-3

## H

Height, A-3

Host computer, 2-7, 7-5, 7-10,  
A-10-A-11

Hue, 6-19

## I

Imaging speed, 3-7

Intensity calibration, A-10

Internal calibration, 7-6

Internal film number, 4-7

Internal termination, 2-8, 2-10,  
7-10

Internal terminator, 3-8

## L

Line voltage, 7-4

Loading film, 4-2

Look-up table, 3-7, 4-8, 7-8,  
A-10

LUT, see *Look-up table*

## M

Mac Conductor, 5-5  
Macintosh, 2-11  
Measured density, 6-2, 6-7  
Medium format module, 1-4  
MENU button, 1-7  
Message window, 1-7  
Midtones, 6-14

## N

Neutral gray tone scale, 6-19  
NEXT button, 1-7

## O

Optima film, 4-7

## p

Pacing, 3-7, 7-10  
    control, 5-3  
    PACING HS, 5-3  
    values, 5-5  
PCs and PC compatibles, 2-11  
Peripheral device, A-1 1  
Power cord, 1-2, 7-4  
    connecting, 2-2  
Power indicator, 1-7, 3-2, 7-4  
Power surge, 3-3  
Power switch, 1-9, 3-2

PREVIOUS button, 1-7  
Primary error codes, A-13  
Print films, 6-18  
Product registration card, 1-2  
Professional films, 1-3

## R

Rasterizers, 5-3, 5-5  
Ready message, 3-5-3-6, 3-10  
Rear panel, 1-8  
Repeat values, 3-8  
Repeats, 6-11  
Repeats value, 6-7  
Reset, 3-11  
RESET button, 1-7  
Reset procedures, 7-7  
Resetting defaults, 3-11  
Resolution, 3-8, 5-6, 6-5  
Response curve, 6-3

## S

SCSI, 2-4, A-1 1  
    address, 2-12  
    cable extender, 2-6  
    device, A-1 1  
    port, 2-6, 2-7

SCSI chain, 2-4, 2-10  
  cable length, 2-7  
  termination, 2-7, 2-10

SCSI communication, 2-6, 7-10

SCSI device address, 3-7

SCSI system cable, 2-6

SCSI Interface Ports, 1-9

Secondary error codes, A-13

SELECT button, 1-7

Shades of gray, A-4

Slide films, 6-20

Socket, 1-9

Static discharge, 7-5

Status messages, 7-2

Surge protection, 7-4

## T

Target device, 2-4

Termination, 2-10

Test images, 3-8, 6-5

Unloading film, 4-3

User film type, 4-7

User memory locations, 4-8

User programmable settings, A-5

## V

Vericolor film, 4-7

Voltage spikes, 7-4

## W

Warm-up, 3-10, 5-2  
  sequence, 3-2, 3-3, 6-17

Weight, A-3

Width, A-3

# **PCR II Plus**

## **35mm Camera Module**

### ***User Guide***

Part Number  
M00009-001



Part Number M00009-001

Copyright © 1995 by Bayer Corporation. All rights reserved.

This document was prepared by Customer Documentation, Agfa Division, Bayer Corporation. Illustrations are meant to be representative of, but not duplicates of, actual equipment and software. Agfa shall not be responsible for any errors or omissions. Please report any errors to Customer Documentation, Agfa Division, Bayer Corporation, 200 Ballardvale Street, Wilmington, Massachusetts 01887.

For complete disclaimer and trademark information, refer to the PCR II Plus User Guide, Part Number 209649.

# Table of Contents

Introduction.....	1
Attaching the Module.....	2
Removing the Module.....	3
Loading Film.....	4
Unloading Film .....	6

# Introduction

This document is to be used with the *PCR II Plus User Guide* (#209649-002). It describes the operation of the 35mm camera module designed for use with the PCR II Plus film recorder and contains the following information:

- How to attach the camera module
- How to remove the camera module
- Loading fresh film into the module
- Removing exposed film from the module

# Attaching the Module

If there is a camera module currently mounted on the PCR II Plus, follow the instructions in the next section, *Removing the Module*, to remove it.

Follow this procedure to attach the 35mm camera module:

**Step 1:** Clean any dust from the circular glass plate in the center of the recessed area on the PCR II Plus.

**Note:** If there are finger prints or dirt on the glass plate, use the same cleaning materials and techniques you would use for cleaning a camera lens.

**Step 2:** Align the module inside the recessed area on top of the PCR II Plus. The module plate fits tightly on the two registration pins on the film recorder, and it can only be oriented in one direction. See Figure 1.

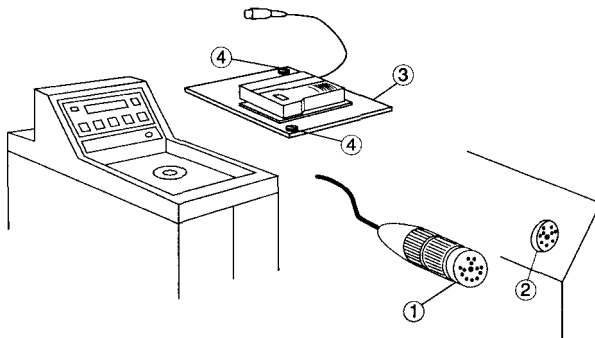

Figure 1. Attaching the camera module.

①-Module cable connector. ②-Module cable receptacle.

③-Module plate. ④-Thumb screws.

**Step 3:** Push down both thumb screws on the module plate and turn them clockwise until they are tight.

**Step 4:** Insert the module cable connector into the module cable receptacle. Tighten the connector by turning the outer ring clockwise.

# Removing the Module

Step 1: Carefully unscrew the locking ring on the module cable connector and pull it straight out. Do not pull on the cable because this can damage it. See Figure 2.

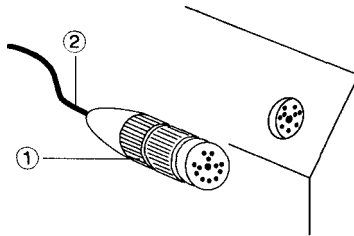

*Figure 2. Removing the camera module.*  
①-Module cable connector locking ring,  
②-Module cable.

Step 2: Find the two thumb screws on the opposite corners of the module plate—see Figure 1. Turn the screws counterclockwise until they are loose. This releases the camera module assembly from the PCR II Plus.

Step 3: Lift the module straight up to remove it from the PCR II Plus.

**Note:** After you remove the camera module, store it so that the lens is protected from dust, dirt, and contact with any objects.

# Loading Film

To load film in the 35mm camera module:

- Step 1: Make sure that the PCR II Plus is powered on.
- Step 2: At the PCR II Plus control panel, press MENU, then NEXT or PREVIOUS until the message LOAD FILM appears.
- Step 3: Press SELECT to start the film loading sequence. The film recorder:
- Resets the frame counter to 1.
  - Clears the end-of-film condition.

**Note:** If you use film canisters loaded from bulk film, use the ADVANCE FILM command to advance the film two more times to ensure that the first exposure is made on unexposed film. See the section *Advancing Film, Chapter 4: Film Control*, in the *PCR II Plus User Guide*.

- Step 4: Open the camera back by sliding the latch, located on the left side of the camera. See Figure 3.

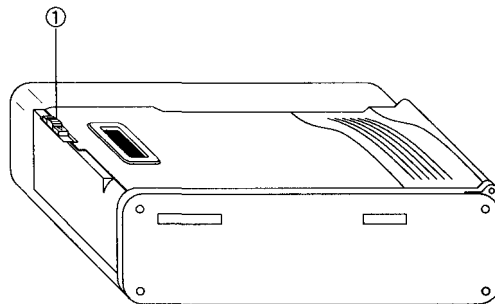

Figure 3. Camera back.  
①-Latch.

Step 5: Insert the film cartridge into the chamber and pull the film across, so that the top edge passes under the film leader guide as shown in Figure 4.

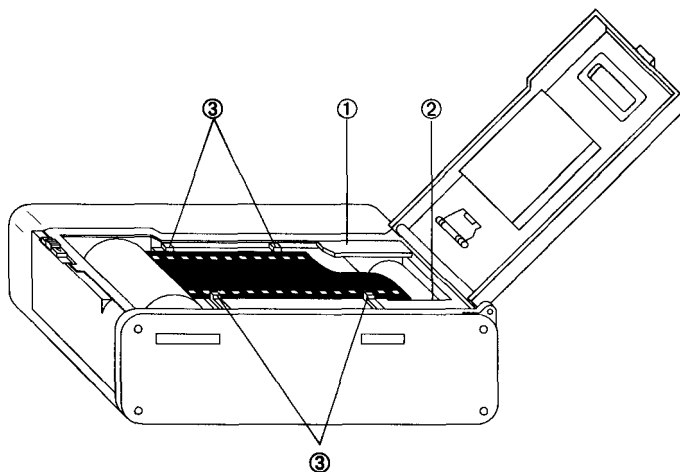

Figure 4. Loading film.

①-Film leader guide. ②-Film leader mark.

③-Film edge guides.

Step 6: Align the end of the film with the film leader mark. Position the film flat between the film edge guides.

Step 7: Close the camera back until it clicks shut. If the film is loaded properly, the camera will automatically wind the film to the end of the roll to prepare for the first exposure.

**Note:** After you close the camera back, the film is wound to the end of the roll. After each exposure, the film is advanced to the next frame by winding it back into its cartridge. After the last frame is exposed, the film is ready to be removed from the camera. If an automatic slide mounter is used, it should be set for reverse numbering.

# Unloading Film

After the last exposure on the roll is made, wait for the film to wind into its cartridge, then unload the film from the camera back. You can also unload the film at any point on the roll if you have finished the current job.

To unload the film after exposing the entire roll:

- Step 1: After exposing the last frame on the roll, the film is wound into its cartridge, and you see the END OF FILM message in the film recorder message window.
- Step 2: Open the camera back and remove the exposed film. Place it in a safe place until processing.
- The END OF FILM message in the film recorder message window will clear after loading a new roll and executing the LOAD FILM command. You can also clear the message by pressing RESET.

To unload the film before the end of the roll:

- Step 1: Locate the recessed film rewind button on the left side of the camera. See Figure 5.

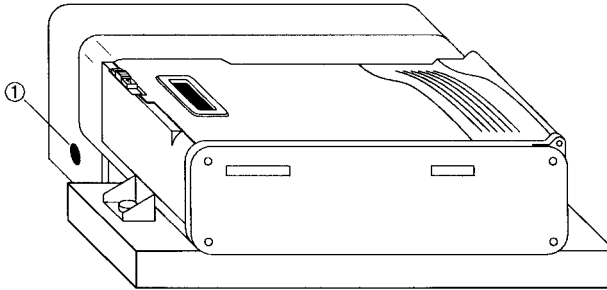

Figure 5. Manual film rewind.

①-Film rewind button.

- Step 2: **Press the recessed rewind button for at least five seconds with the point of a pen or pencil.**

- Step 3: After the camera module motor stops and the film is re-wound, open the camera back and remove the exposed film. Place it in a safe place until processing.
- If the display shows an END OF FILM message, the message will clear upon loading a new roll and executing the LOAD FILM command. You can also clear the message by pressing RESET.

# **PCR II Plus**

## 120/220 Camera Module

### *User Guide*

Part Number  
209889-001



Part Number 209889-001

Copyright © 1994 by Bayer Corporation. All rights reserved.

This document was prepared by Customer Documentation, Agfa Division, Bayer Corporation. Illustrations are meant to be representative of, but not duplicates of, actual equipment and software. Agfa shall not be responsible for any errors or omissions. Please report any errors to Customer Documentation, Agfa Division, Bayer Corporation, 200 Ballardvale Street, Wilmington, Massachusetts 01887.

For complete disclaimer and trademark information, refer to the PCR II Plus User Guide Part Number 209649.

# Table of Contents

Introduction.....	1
Attaching the Camera Module.....	2
Removing the Film Cartridge.....	3
Changing Between 120 and 220 Film.....	4
Loading the Film Cartridge.....	6
The Camera Module Reset Button .....	9
Using the 120/220 Module .....	10
Unloading the Film .....	11
Removing the Camera Module.....	12

# Introduction

This document is a supplement to the *PCR II Plus User Guide*. It describes the operation of the optional 120/220 camera module designed for use with the PCR II Plus film recorder and contains the following information:

- How to attach the camera module.
- How to remove the film cartridge from the camera module.
- Adjusting the film cartridge pressure plate to accommodate 120 or 220 film.
- Loading the film cartridge.
- Using the 120/220 camera module.
- Removing exposed film.

# Attaching the Camera Module

Follow this procedure to attach the 120/220 camera module to the PCR II Plus:

- Step 1: Align the camera module inside the recessed area on top of the PCR II Plus. The module fits tightly on the two registration pins and can only be oriented in one direction.
- Step 2: Secure the module by turning both locking screws clockwise until they are tight.
- Step 3: Insert the module connector into the camera receptacle on the front panel of the PCR II Plus. Tighten the connector by turning the outer ring clockwise.

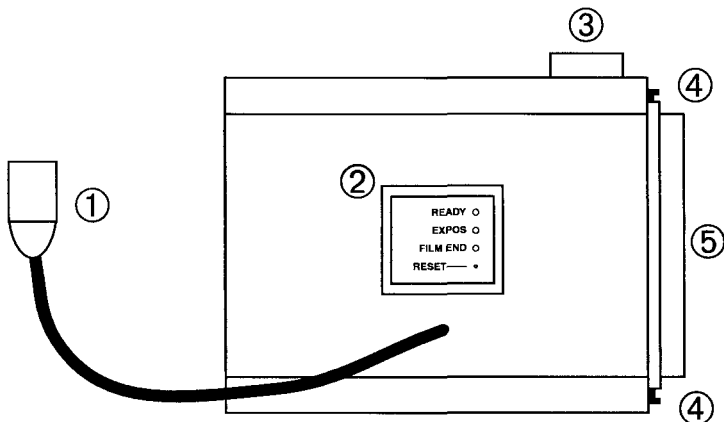

Figure 1. Rear view of the PCR II Plus 120/220 camera module.

- ① — Module connector. ② — LEDs and reset button. ③ — Film advance knob.  
④ — Latches. (Note that there are two.) ⑤ — Dark slide.

# Removing the Film Cartridge

The film cartridge is a unit inside the 120/220 module that holds the film. You need to remove it from the module to load and unload film.

- Step 1: Make sure the PCR II is turned on.
- Step 2: Locate the back lock releases on the right side of the camera module, then slide them outward.
- Step 3: Open the back of the module and lift the film cartridge up and out.

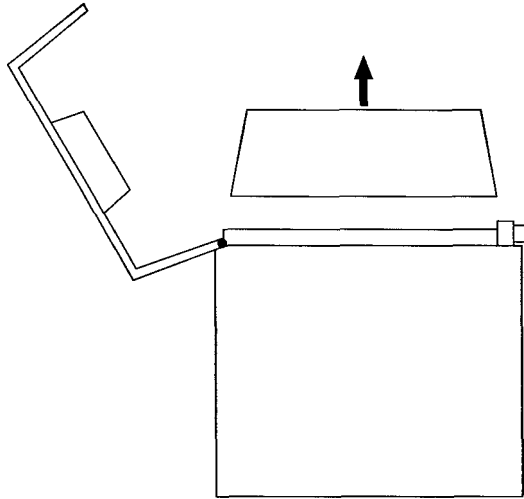

*Figure 2. Open the back of the module and lift the film cartridge up and out.*

# Changing Between 120 and 220 Film

The 120/220 camera module can use either 120 or 220 roll film. You need to change the position of the film cartridge pressure plate to match the type of film you are using. Change the pressure plate position before you complete the film loading procedure or when the cartridge is empty. Follow this procedure:

- Step 1: Remove the film cartridge from the 120/220 module.
- Step 2: With your fingertips, push in the pressure plate selector dial (Ⓟ in Figure 3). This lifts the pressure plate up and away from the other side of the cartridge.

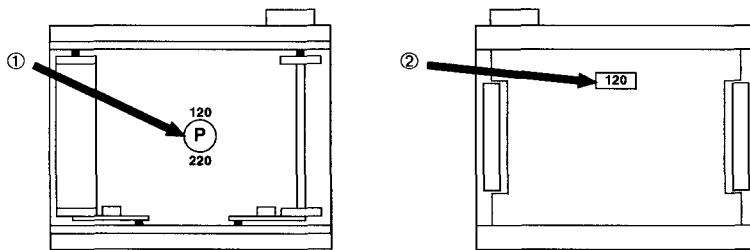

Figure 3 The pressure plate selector dial (Ⓟ) and pressure plate in position for 120 film. A window (Ⓢ) in the pressure plate displays the current film size.

- Step 3: While pushing the selector dial, rotate it 180 degrees.

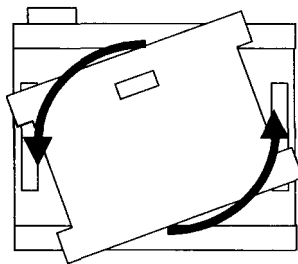
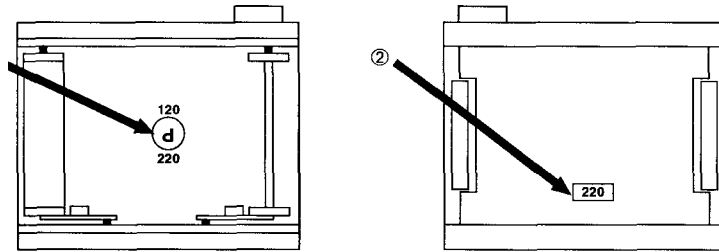

Figure 4 Push in the pressure plate selector dial and rotate it 180 degrees.

**Step 4: Make sure the pressure plate is seated firmly.**



*Figure 5. The pressure plate selector dial (①) and pressure plate in position for 220 film. A window (②) in the pressure plate displays the current film size.*

# Loading the Film Cartridge

- Step 1: Remove the empty spool from the left side of the cartridge. Lift the left metal tab (① in Figure 6) to loosen the spool, then remove the spool from the left upper film stud (②).

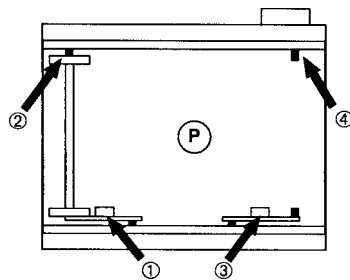

Figure 6. Remove the empty film spool.

- Step 2: Lift the right metal tab (③ in Figure 6) and insert the empty spool onto the right upper film stud (④). Lower the tab and insert the lower film stud into the spool.

- Step 3: Insert a new roll of film into the left side of the cartridge. Seat the new roll on the left upper film stud, then lower the left tab and seat the bottom end of the new roll of film on the bottom film stud.

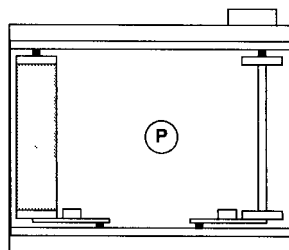

Figure 7.

Step 4: Unwrap the new roll of film and feed it around the cartridge. See Figure 8. The tab in the roll of film fits into a slot on the empty spool.

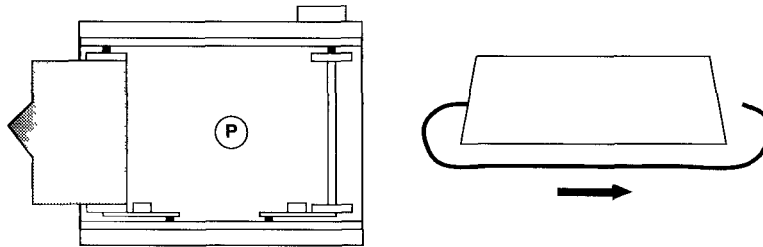

Figure 8.

Step 5: Turn the film advance knob to wind the film securely onto the empty spool. Advance the film until an arrow printed on the film backing appears. Stop when the arrow lines up with the arrow stamped on the left metal tab (① in Figure 9).

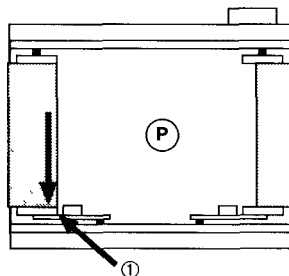

Figure 9.

Step 6: Place the film cartridge into the opening of the film cassette. Close the back cover, hold it in place, and push both of the back cover latches in to close them.

Step 7: Execute a load film command from the PCR II Plus front panel.

- Press MENU once, then press PREVIOUS or NEXT until the message window displays LOAD FILM SELECT FUNCTION.
- Press SELECT to execute the LOAD FILM command. This advances the film to the first frame, resets the PCR II Plus frame counter to one (#1) and clears the end-of-film condition.
- Press MENU once to return to the ready condition.

Step 8: Press the start button located next to the film advance knob on the 120/220 camera module. See Figure 10. The READY indicator LED on the back of the module will light up. See Figure 11.

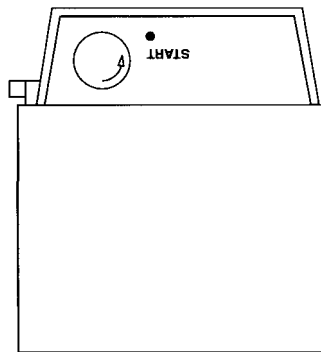

Figure 10. To complete the film loading procedure, press the start button.

## The Camera Module Reset Button

If the ready light does not illuminate after you complete the film loading procedure, press the reset button on the back of the camera module. See Figure 11.

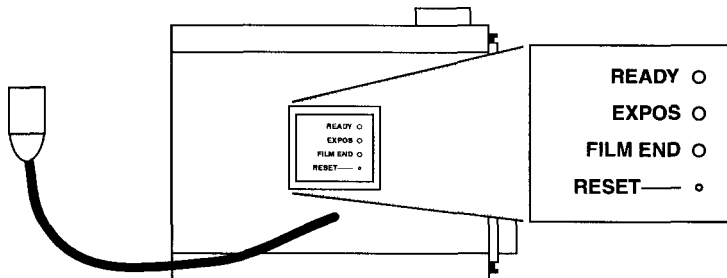
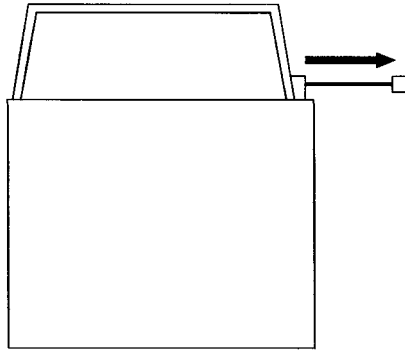

Figure 11. Indicator lights and reset button on the 120/220 camera module.

# Using the 120/220 Module

Step 1: Before making exposures, remove the dark slide as shown in Figure 12.



*Figure 12. Remove the dark slide before you make exposures.*

Step 2: Make exposures as desired. When you use the last frame on a roll of film, the FILM END indicator LED lights up.

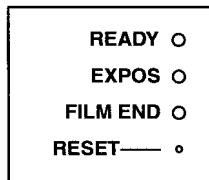

*Figure 13. Indicator Lights on Back of Module*

Step 3: If you did not use the entire roll of film, use the PCR II Plus front panel controls to advance film to the end of the roll.

Step 4: Replace the shutter.

# Unloading the Film

- Step 1: Slide both back lock release latches outward.
- Step 2: Open the camera back and lift the film cartridge up and out of the camera chamber.
- Step 3: Remove the film. Make sure that the film does not unroll or become loose.
- Step 4: Remove the empty spool from the film cartridge, replace it on the right-hand side so that it becomes the take-up spool.

When you open the back cover, the exposure counter automatically returns to 'S' (Start). If anything other than 'S' appears in the exposure counter, it indicates there is film in the cassette. Always check the exposure counter before you open the back cover.

# Removing the Camera Module

Follow this procedure to remove the 120/220 camera module from the PCR II Plus:

**Step 1:** Loosen the locking ring on the module connector, then pull the connector out of the camera receptacle on the front panel of the PCR II Plus. Pull the module connector out of the receptacle.

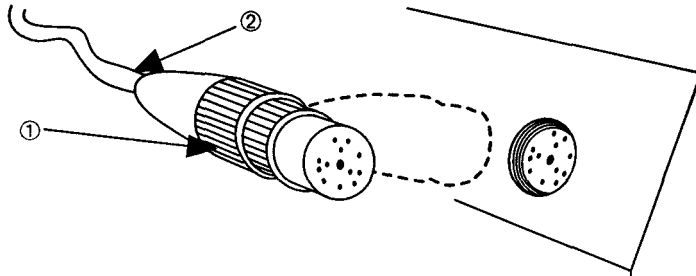

Figure 14. When removing the camera module from the PCR II Plus, loosen the locking ring (1) on the module connector. Do not pull on the cable (2) when removing the plug.

## **Caution:**

Pull the body of the connector plug. Do not pull the cable to remove the module connector from the receptacle.

**Step 2:** Loosen both locking screws that hold the camera module in place on the PCR II Plus.

**Step 3:** Lift the camera module up and off the film recorder.

**PCR II Plus**  
**35mm Bulk Load**  
**Camera Module**  
*User Guide*

Part Number  
209865-001



Part Number 209865-001

Copyright © 1994 by Bayer Corporation. All rights reserved.

This document was prepared by Customer Documentation, Agfa Division, Bayer Corporation. Illustrations are meant to be representative of, but not duplicates of, actual equipment and software. Agfa shall not be responsible for any errors or omissions. Please report any errors to Customer Documentation, Agfa Division, Bayer Corporation, 200 Ballardvale Street, Wilmington, Massachusetts 01887.

For complete disclaimer and trademark information, refer to the PCR II Plus User Guide, Part Number 209649.

# Table of Contents

Introduction.....	1
Installation .....	2
Controls and Indicators .....	3
StatusIndicatorLights.....	3
Keypad Controls.....	4
Loading Film.....	6
Loading the Feed Magazine.....	6
Threading film Through the Module Body.....	9
Loading Film into the Take-up Magazine .....	10
Unloading the Film .....	11
Using Standard 35mm Cassettes .....	12
Loading a 35mm Cassette .....	12
Unloading a 35mm Cassette.....	14

# Introduction

This document is a supplement to the *PCR II Plus User Guide*. It describes the operation of the optional 35mm bulk load camera module designed for use with the PCR II Plus film recorder and contains the following information:

- How to attach the camera module to the PCR II Plus.
- The meaning of the camera module status indicator lights and functions of the keypad controls.
- How to load bulk film into the camera module.
- How to unload bulk film from the camera module.
- How to load and unload standard 35mm cassettes from the camera module.

# Installation

Follow this procedure to install the 35mm Bulk Load Camera Module on the PCR II Plus film recorder:

Step 1: Remove the protective plastic cover from the lens in the 35mm bulk load camera module mounting plate assembly.

**Caution:**

Do not attempt to disassemble the mounting plate assembly. This assembly has been adjusted and aligned during manufacturing.

Step 2: Align the mounting plate inside the recessed area on top of the PCR II Plus. The module fits tightly on the two registration pins and can only be oriented in one direction.

Step 3: Use the provided thumb-screws to secure the mounting plate to the film recorder. Turn both screws clockwise until they are tight.

Step 4: Make sure that the top of the mounting plate is clean and dust free, then attach the film transport. Align the  $\frac{1}{4}$  inch mounting pins on the mounting plate with the corresponding holes in the bottom of the film transport. Make sure that the transport is seated securely on the mounting plate.

Step 5: Use the provided 10-32 x  $\frac{1}{2}$  inch alien cap screws to attach the film transport to the mounting plate.

Step 6: Plug the small male end of the module connector cable into the top female connection at the back of the film transport.

**Note:** The bottom female connection at the back of the film transport is not used with the PCR II Plus.

Step 7: Plug the right angle male end of the cable into the camera receptacle on the front panel of the PCR II Plus. Tighten the connector by turning the outer ring clockwise.

# Controls and Indicators

This section describes the 35mm Bulk Load Camera Module keypad controls and LED indicator lights.

## Status Indicator Lights

There are four LEDs on the side of the camera module. The following descriptions explain what the LEDs mean when they light up.

**Expose:** An exposure is in progress.

**End of Film:** The camera is out of film.

**Double Exposure:** Double exposure is active. Film is advanced only after every second exposure.

**Auto-mark:** Auto-mark is active. Three blank frames are advanced after every 36 exposures. The film is marked in the middle of the three blank frames to indicate where to cut.

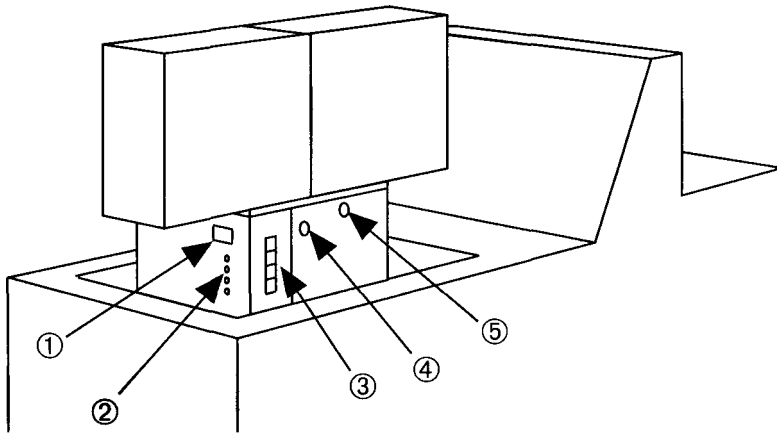

Figure 1 ①— LCD that displays the current frame number

② — Status indicator LEDs on the side panel

③ — The keypad Keys are labeled A, B, C, and D from top to bottom

④ — Rewind knob ⑤ — Latch

## Keypad Controls

There are four keys on the keypad. They are identified by the letters A, B, C, and D. Press different key combinations to perform different operations.

In the illustrations that accompany the descriptions below, the grayed out boxes represent the key or keys that you need to press.

**A: Jog Forward**—Advances the film by one frame. If you hold down key A, the module continues to advance film until you release the key.





**B: Mark**—Advances 1.5 frames, marks the film, then advances another 1.5 frames.





**C: Auto-mark**—Advances 1.5 frames, marks the film, then advances another 1.5 frames. Automatically repeats the mark operation again after 36 frames have been imaged. Continues until disabled. To disable auto-mark, press C again.





**D: Format**—Not implemented.

Press D and another key at the same time to perform additional functions.

**Note:** Pressing D alone has no effect.

 **D+G: Load**—Advances six frames without making an exposure.  
  
  

 **D+F: Reset Counter**—Resets the camera module frame counter to zero.  
  
  

 **D+E: Double Exposure**—The camera exposes two images before it advances film. Continues until disabled. To disable double exposure, press D and C again.  
  
  

# Loading Film

The procedure to load a 100 foot (30 meter) bulk roll of film into the 35mm Bulk Load Cassette consists of these major steps:

1. Load the feed magazine.
2. Thread the film through the body of the module.
3. Thread the film into the take-up magazine.

Figure 3 on page 8 identifies the parts of the module and shows the film path.

## Loading the Feed Magazine

Follow this procedure to load the feed magazine:

Step 1: Remove the feed magazine from the camera module.

- Before you begin loading film, open the empty feed magazine and get acquainted with the parts of the assembly.

**Caution:**

Perform steps 2 through 7 in a film changing bag or in a darkroom.

Step 2: Unwrap the bulk roll of film. Place the film and core onto the plastic film spool.

- Bulk rolls of 35mm film are wound around a small plastic core.
- The plastic film spool comes with the camera module and is stored inside the feed magazine.

Step 3: Rotate the core until the spool alignment screw lines up with the slot in the core.

- Step 4: Place the film, core and spool combination into the magazine.
- Step 5: Thread the film through the light seal rollers at the bottom of the magazine.
- Step 6: Pull about 12 inches (30 cm) of film out of the magazine. This is the film that you will thread through the body of the module and into the take-up magazine.
- Step 7: Close the magazine door.

**Note:** Steps 8 and 9 can be performed in subdued room light.

Step 8: Prepare the end of the leader:

- Cut the end of the film as shown in Figure 2.
- Make a reverse bend at the end of the leader as shown in Figure 2. The reverse bend makes it easier to feed the film through the light seal rollers of the take-up magazine.

Step 9: Mount the feed magazine onto the module and feed the film into the body of the module.

**Caution:**

Do not leave loaded feed magazines in brightly lit areas for long periods of time.



*Figure 2 Left, cut off the corners of the leader to make it easier to thread the film through the camera module Right, make a reverse bend at the end of the leader to make it easier to feed the film into the take-up magazine*

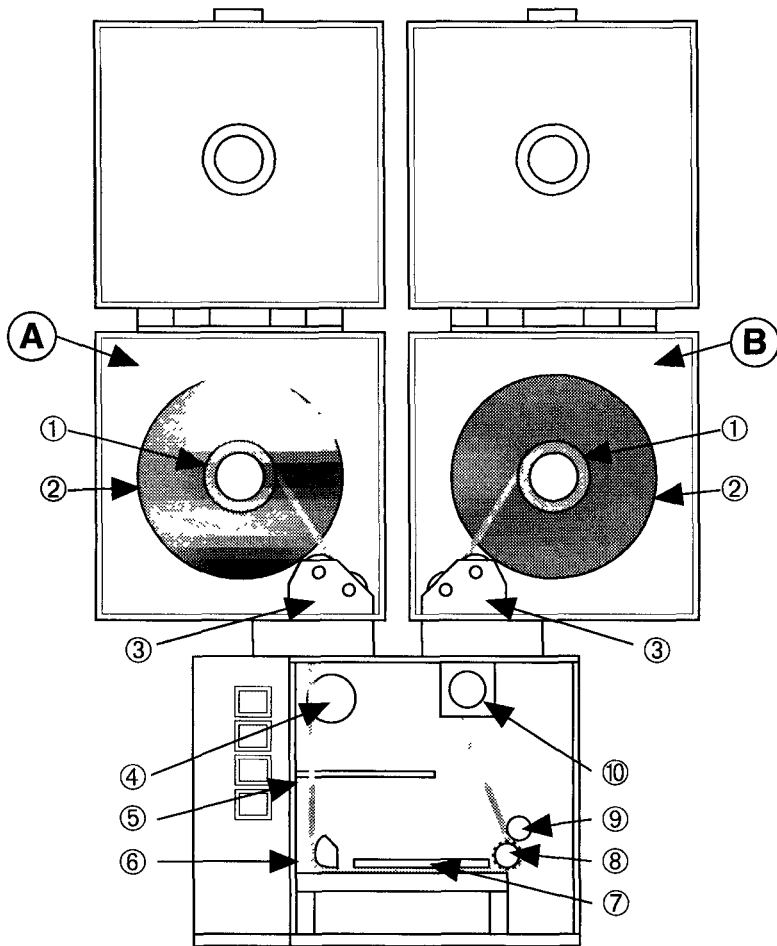

Figure 3. Parts of the 35mm bulk load camera module.

**A** — Feed magazine. **B** — Take-up magazine.

① — Film core. ② — Film spool. ③ — Light seal rollers.

④ — Film cassette recess. ⑤ — End of film sensor switch. ⑥ — Film guide.

⑦ — Pressure plate. ⑧ — Drive sprocket. ⑨ — Film guide roller. ⑩ — Light trap.

## Threading Film Through the Module Body

Figure 3 identifies the parts of the camera module and shows the film path.

Follow these steps to thread the film through the body of the module:

Step 1: Feed the entire leader into the camera body.

Step 2: Thread the film through the body so that it follows this path:

- Under the film guide.
- Under the pressure plate.
- Up and between film guide roller 3 and the drive sprocket.

Make sure that:

- The edge of the film presses against the end of film sensor switch.
- The sprocket holes in the film line up with the teeth on the drive sprocket.

Step 3: Remove the take-up magazine from the camera module.

Step 4: Feed the film up through the light trap so that at least 6 inches (15 cm) protrude up from the camera body.

Step 5: Make sure the film is threaded correctly through the camera body:

- Examine the film path. Make sure that the film is snug against the film guide rollers and the drive sprocket.
- Press down on the pressure plate.

Step 6: Press the jog forward button a few times to advance a few frames and make sure that the film is moving properly.

Step 7: Close the camera door.

## Loading Film into the Take-up Magazine

Follow this procedure to thread the film into the take-up magazine:

**Note:** Before you begin, make a reverse bend in the leader as shown in Figure 2.

- Step 1: Thread the film through the light seal rollers.
- Step 2: Attach the take-up magazine to the camera body. Make sure that the film is not pinched between the camera and the magazine.
- Step 3: Pull the film into the magazine and use a piece of tape to attach the end to the plastic core. Attach the film so that it will wind in a counterclockwise direction. See Figure 3.
- Step 4: Press the jog forward button a few times to advance a few frames and make sure that the film is moving properly.
- Step 5: Close the magazine door.
- Step 6: Using the keypad Load function, advance unexposed film to frame number 1.

# Unloading the Film

Follow this procedure to unload film:

Step 1: When you are ready to unload, press key A on the camera module keypad. This advances the film 6 frames, which moves the last exposed image from the camera body into the take-up magazine.

**Note:** As a precaution, advance a few extra frames into the take-up magazine to prevent exposing the last image to light.

Step 2: Press the take-up magazine safety latch on the back of the magazine. Lift the magazine and cut the film with a pair of scissors.

**Caution:**

To help keep the exposed film from being exposed to light, do not lift the take-up magazine more than one inch from the camera body.

Step 3: Remove the exposed film from the take-up cassette. Use a film changing bag or work in a darkroom.

# Using Standard 35mm Cassettes

This section describes how to use a standard roll of 35mm film in the bulk load camera module.

You can expect to image about 28 frames on a 36 exposure roll of film or 16 frames on a 24 exposure roll. For most efficient operation, use full-length bulk rolls.

## Loading a 35mm Cassette

Follow this procedure to load a 35mm cassette:

- Step 1: Place the film cassette into the film cassette recess in the camera body.
- Step 2: Position the cassette so that the film exits at the eight o'clock position.
- Step 3: Thread the film along the same path you follow when loading bulk rolls of film. See Figure 4. Follow the instructions in the section *Loading Film* in this document.
- Step 4: Make sure that the film makes contact with the out of film switch.

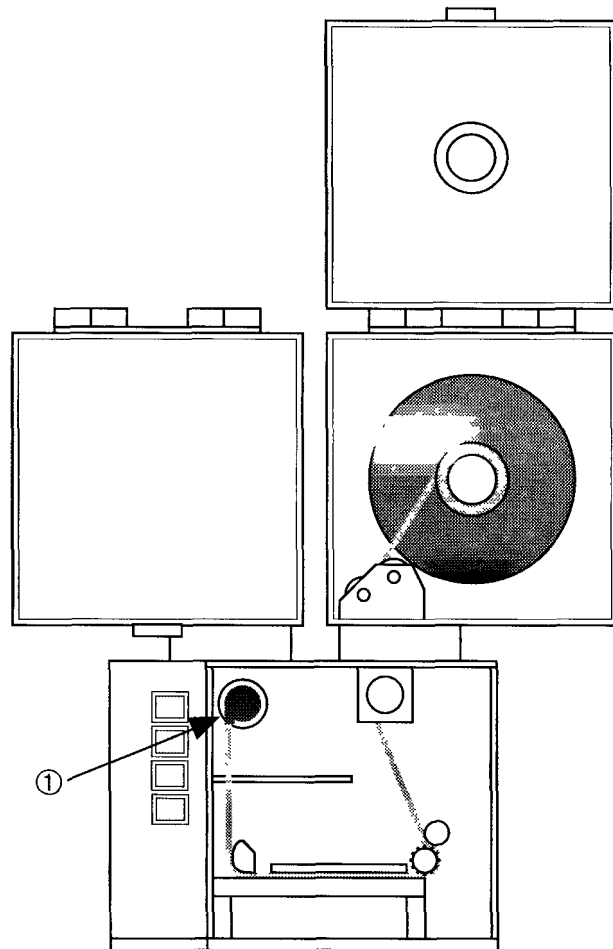

Figure 4. You can use standard rolls of 35mm film in the bulk load camera module.  
① —Film cassette recess holding a 35mm film cassette.

## Unloading a 35mm Cassette

Follow this procedure to unload a 35mm cassette:

- Step 1: Turn off the drive sprocket motor. There are two ways to do this:
- You can turn off the power to the camera.
  - You can advance the film to the end of the roll. This automatically shuts off the drive sprocket motor.
- Step 2: With the motor off, manually rewind the film back into the cassette. Follow the rotation direction marked on the camera door.

**Caution:**

When unloading hand-rolled film cassettes, take care that the cassette does not come apart.

# Other ManualsLib Projects



[www.manualslib.com](http://www.manualslib.com)



[www.manualslib.de](http://www.manualslib.de)



[www.manualslib.es](http://www.manualslib.es)



[www.manualslib.fr](http://www.manualslib.fr)



[www.manualslib.nl](http://www.manualslib.nl)



[www.manualslib.mx](http://www.manualslib.mx)



[www.manualslib.tech](http://www.manualslib.tech) 30+ Languages